



**Relentless Innovation
Uncompromising Quality
Comprehensive Service**



DOMBOR VALVE BROCHURE

Generating high-quality valve solutions requires a deep insight into market needs. DomBor Valve, as a reliable valve manufacturer, relies on a trusted supply network, the latest production, and assembly machinery, along with digital design capabilities and 20 years of industry experience.

Dombor



“Together with our partners, we aim for cleaner production displaying our strong commitment to sustainable business, mindful of the future.”

-Sea Zhang
CEO of DomBor Valve





Catalog

01 About Dombor	_____	01
02 Our Partners	_____	05
03 Manufacturing	_____	09
04 Quality Control	_____	13
05 Product Categories	_____	19



Part One

About Dombor

Premier Manufacturer of High-quality Custom Valves

Founded in 2001, DomBor prides itself on being a premier manufacturer of high-quality custom valves. Working with modern technology and advanced production equipment, we specialize in manufacturing a diverse array of industrial valves capable of handling severe working conditions and perfect for industrial applications.

Constantly pushing the bar in custom valve manufacturing, our expert engineers seek answers to upcoming concerns in the industry. Diligence in research and development allows us to address those concerns and deliver exceptional wholesale valves for refineries, treatment plants, mining facilities, and others.



DomBor Valve

Grow Through Innovative Changes.

DomBor Valve continues to excel in trend-setting R&D and sustainability practices to reduce costs and ensure optimal performance for every valve product.

Meanwhile, cutting-edge developments in our product design and manufacturing process have allowed us to earn numerous intellectual property rights and quality certifications.



Professional Service

Providing constant feedback over our production cycle, our team also handles on-site technical training and support for timely transactions.



Production Strength

With a factory employing 5 production lines and numerous machines, we easily produce up to 8,000 tons of valves annually.



Strict Quality Control

Together with third-party inspection teams, we use advanced testing equipment in our certified laboratory to test every valve before delivery.



R&D Capabilities

With over 15 years of experience, our team continues to manufacture the latest valve solutions based on market trends and industry challenges



20 Years of Experience

Since 2001, we have been running an efficient production system acquiring patents and continually innovating our valves for efficient global resource deliveries.

DomBor History

“We never strayed from the promise we made years ago to create optimized, affordable, and tailor-made products. We create valves, not for the sake of profit, but the betterment of every business around the world.”

2001 - 2009

Gavin and Sea established DomBor, an industrial valve brand for a wide business range in 2001. In the following years, we passed the ISO9001 quality management system certification by making our production capabilities compliant with global standards as well as passing TS-related certification.

2010 - 2016

The creation of our full series of hard-sealed butterfly valves was successfully developed during 2010-2011. In 2015, we produced our first ultra-high-pressure 1500# valve and the DN2600 (104 inches) large-diameter all-metal flange hard sealed butterfly valve.

2017 - 2019

In 2017, all of our decision-makers decided to relocate part of the factory's equipment to Wenzhou. The non-regional industry company DomBor was established in Wenzhou in 2018. This factory has 20,000 square meters of workspace, high-end processing equipment & testing equipment, and an established valve test center. Till 2019, the company achieved an annual output of 5,000 tons of valves, providing us with good economic benefits.

2020 - Now

In 2020, DomBor obtained a series of national and international authoritative certifications such as the TS license for special equipment manufacturing, CE, API, and SIL3. Since 2020, we have actively responded to the global epidemic, ensuring production and providing high-quality products. DomBor is always on the way to become a better industry leader.

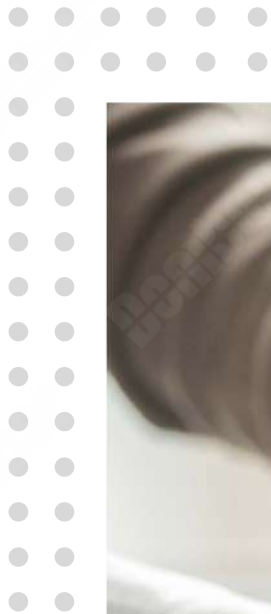

Dombor

Part Two

Our Partners

Win-Win Partnership

With a wide range of industrial valves, DomBor can cooperate with any kind of client.

When you are constructing or forming a valve system, you need a specific solution for your project requirements. DomBor can assist you with our full-service support as well as system maintenance programs for all of your orders.

To provide the right valve solutions for all your customers, you need a diverse range of industrial valves that fits their needs. Working with DomBor gives you a rich selection of pump valves for any of your clients.

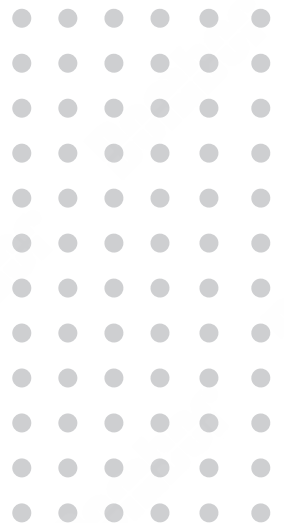



Benefits from Cooperation

Design Confirmation

Expert designers create practical valve designs based on the data acquired during the consultation, along with any special requirements you may have. The completed design is forwarded to you, ensuring that the design specifications capture your unique branding or marketing concepts.

After getting your approval, the design is then forwarded to our production team for sample making.

30-Day Lead Time

Customized valve orders take a maximum of 30 days for completion, including the prototyping phase.

For standard orders, OEM requests, or urgent purchases, our warehouse is packed with stock standard parts, allowing our team to complete your orders within 7 days from the date of your request.



rotork[®]

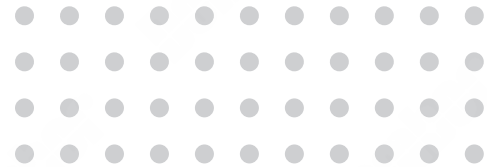

Value-Added Delivery

As we value your business with us, we add free accessories to your purchase at the time of shipment, amounting to 10% of the total order amount.

Per request, we can also include additional documents to the shipment, like product parameters, test results, and other important information.

Responsive After-Sales Service

All valves from DomBor come with a 24-month warranty period that covers technical assistance, on-site repairs, and free product replacements.

Professional aftersales team handles your concerns via email and video calls, while our on-site technical support staff are certified experts in the field and provide fast, effective solutions for any kind of issues.



Domber

Part Three

Manufacturing

Growing Attentive Research and Development Culture

Seeking new and innovative means of improving our products for our clients, DomBor harnesses the power of advanced technology and the latest production equipment to propel its manufacturing capabilities.

Heavy investment in the tools and processes we use, as well as training our team to utilize the technology, results in efficient production and optimized custom valves for the market.

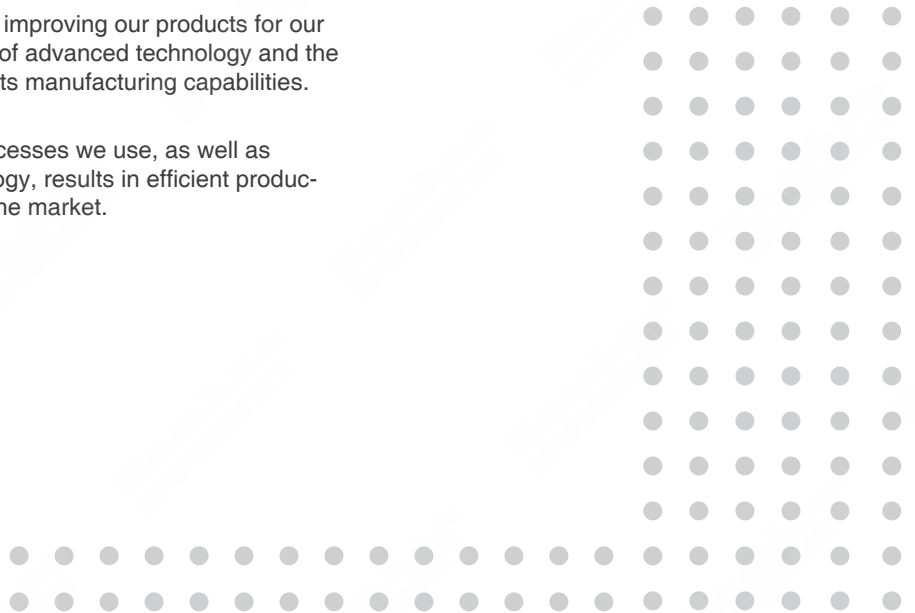

DomBor Valve

DomBor Capabilities at a Glance

A major pillar in our continued success as a global valve manufacturer is our fully-functional production facility, packed with state-of-the-art processing equipment and talented staff.

5

Production Lines

20000 m²

Manufacturing Area

8000tons

Annual Output

\$3200w+

Annual Production Value

Machinery for Highly Efficient Valve Production



52 Sets of CNC Machines



2.5-meter Vertical Lathe

How We Handle Details Makes Us Different

The performance, durability, and service life of DBV industrial valves come from how we process and prepare each of our raw materials: properly, with great attention to detail.

- Rough Machining
- Heat Treating
- Surface Finishing
- Fine Machining
- Boring
- Drilling

We Embrace Tech

DomBor understands that constant innovation is an essential component of satisfying our client's needs and, boosting our growth and success.

Adopting a culture of innovation and development throughout the company, implementing effective management protocols, employing modern production systems, and adhering to quality guidelines—all this enables each of our departments, and our company as a whole, to flourish.



8 Sets of 1.6-meter Vertical Lathes





Dombor

Part Four

Quality Control

We Take Pride in Our High-Quality Work

Understanding how important product quality is to the success of a brand, DomBor places a premium on maintaining high-quality standards in both our valves and our services.

Devoting human and financial resources, along with our commitment to quality, we always perform at our best to manufacture reliable valves that surpass global certification requirements.



DomBor Valve

Making Things Better



Experienced Quality Inspection Team

With over 10 years of experience in the industry, our expert team of quality inspectors has the right skill set to ensure our valves pass global standards.



Professional Laboratory

Product and material testing is handled in-house via our testing laboratory, equipped with the latest testing equipment comparable to third-party professional facilities.



International Certificates

Conducting various tests and witness auditing, we have obtained most completely certificate: API 6D, API609,API607,API6FA,SIL3,CE,ISO9001, ISO18001,TS,CU-TR 010/032,ISO 15848-1(fugitive emission certificate).

Branded and Reliable Raw Materials

Carbon Steel

WCB, LCB, WCC, LC1, A105, LF2

Stainless Steel

CF8, CF8M, CF3, CF3M, 310S, 904L, F304, F316, F304L, F316L, CF8C, F347

Cr-mo Alloy

WC6, WC9, C5, C12A, F11, F22, F5, F91

Duplex Stainless Steel

4A, 5A, 6A, F51, F53, F55, CK3MCUN, CD4MCU, CK20

Copper Alloy

C95800, C95500, C83600

Monel Alloy

MONEL 400, MONEL 500, M35-1

Inconel Alloy

INCONEL600, INCONEL 625, INCONEL 800

Ti Alloy

TITANIUM GR2, GR3, GR5, GR12

Hast Alloy

HAST ALLOY C276

Certified



Key Part of Quality Management and Assurance

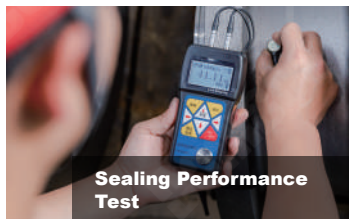
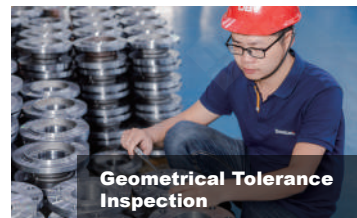



Dombor

Part Five

Product Categories

Well-Engineered Industrial Valves

To address the strict requirements of the market on industrial valves, each DomBor valve is made through our strict QA system.

For specific industry and medium requirements, we create unique valves with a specific appearance, material, and processing technology.

DomBor Valve offers a one-stop-shop for all your valve needs with our extensive selection of butterfly valves, ball valves, gate valves, check valves, and much more. The valve solutions we provide can accomplish your business goals with minimum effort, time, and costs.



DBV BUTTERFLY VALVE DESIGN FEATURE METAL SEAT

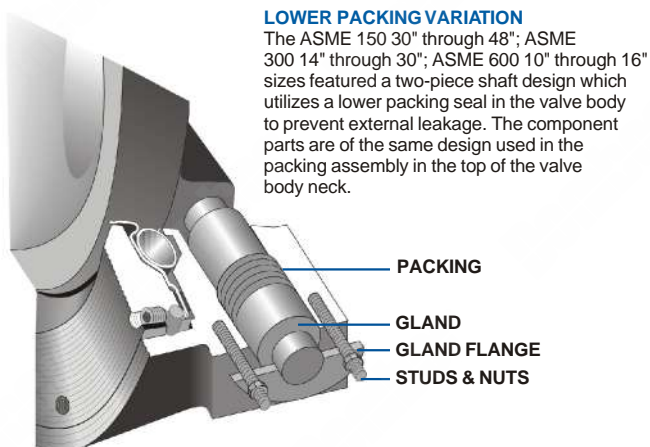
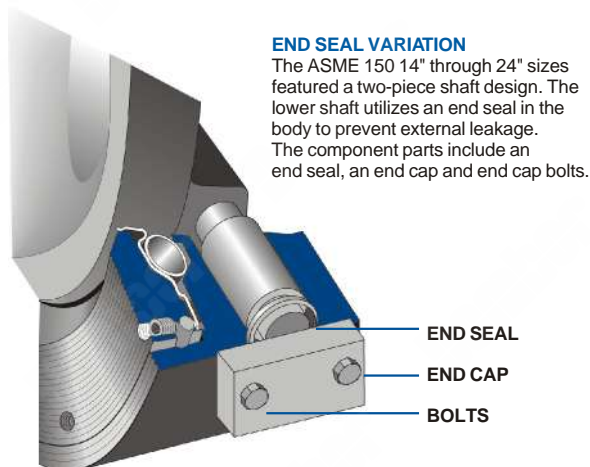
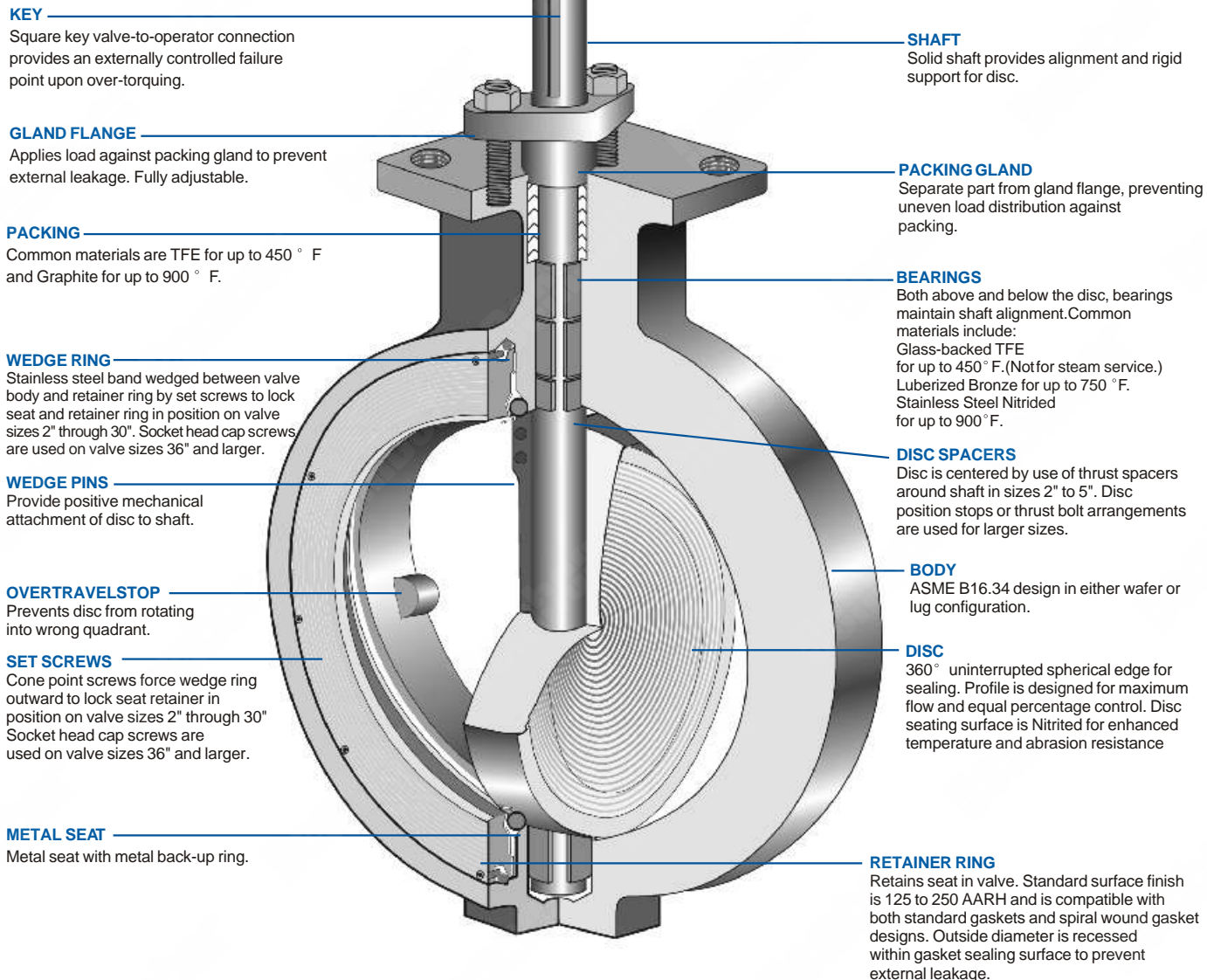

DBV BUTTERFLY VALVE DESIGN FEATURE SOFT SEAT

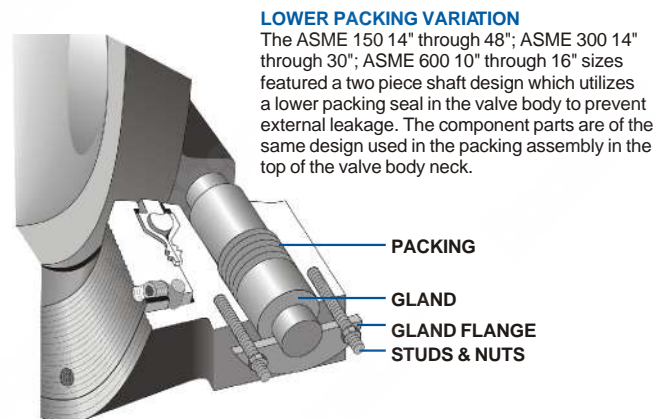
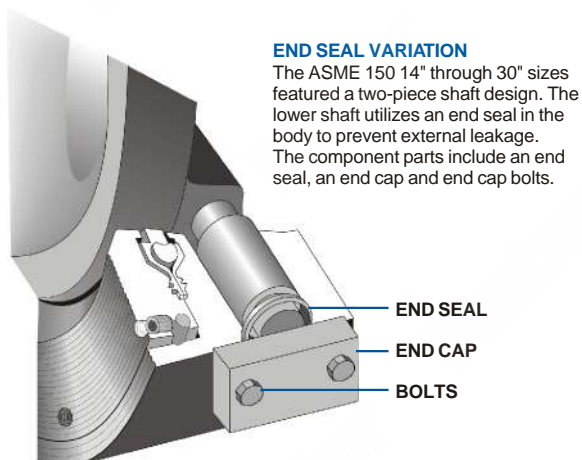
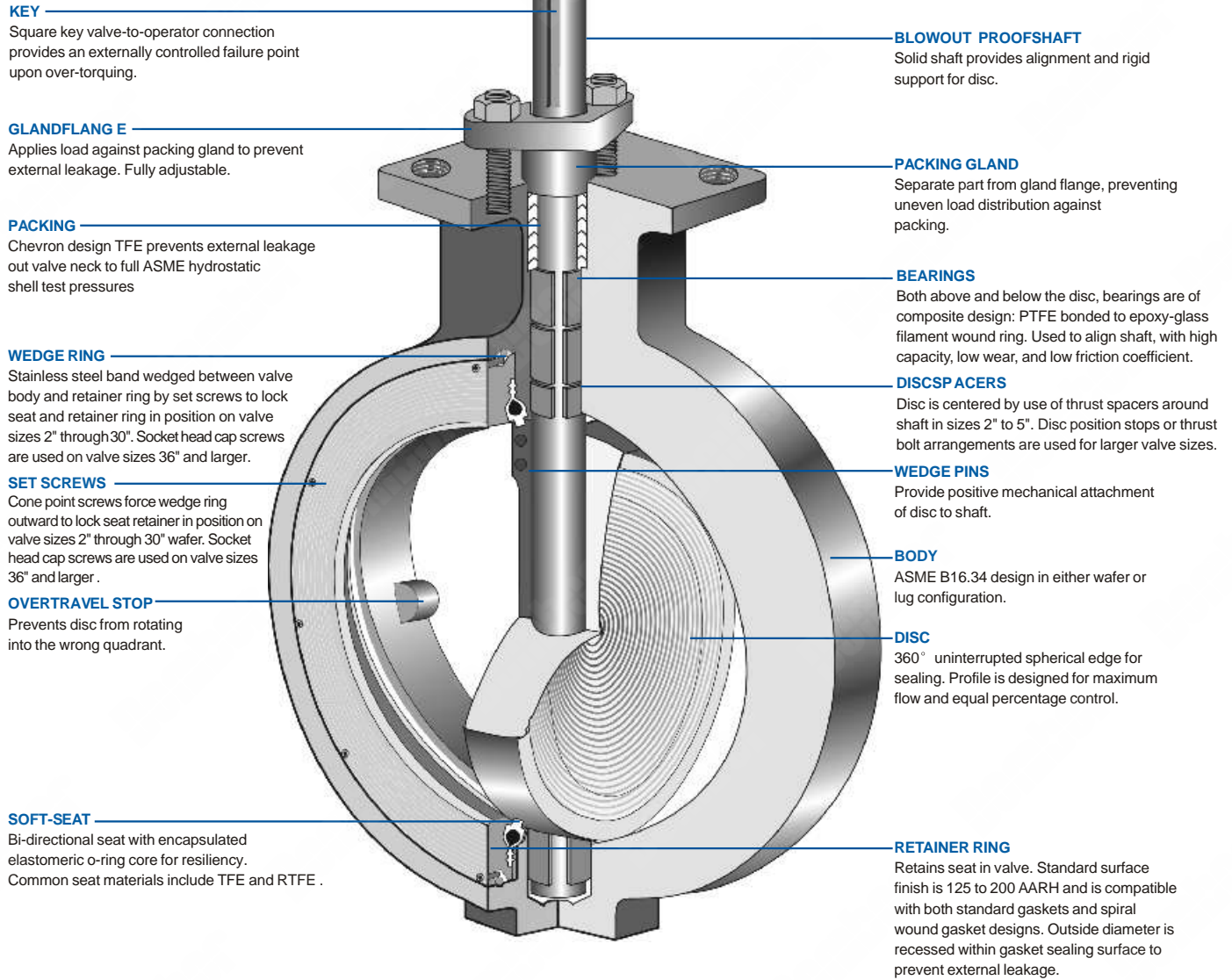

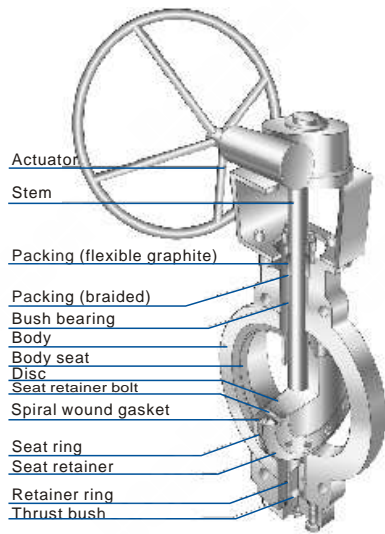

SEAT RING
316 SS+GRAPHITE Laminated

SPIRAL WOUND GASKET
316SS+Graphite

SEAT RING (Solid metal)
316SS+Nitr

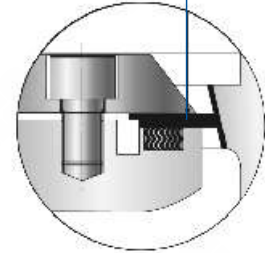
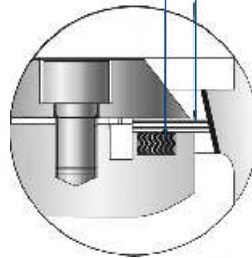

STANDARD MATERIAL LIST-TRIPLE OFFSET METAL SEAT

NO.	PART NAME	MATERIAL TO ASTM			QTY	REMARK
1	BODY	A216-WCB	A217-WC9	A351-CF8M	-	-
2	SEAT SURFACE	316 SS Faced	STELLITE NO. 6 Faced	Integral	1	Note 2
3	DISC	A216-WCB + ENP	A217-WC9 + ENP	A351-CF8M	1	Note 1
4	STEM	A479-410	A479-410	A564-630	1	-
5	RETAINER RING	A479-410	A479-410	A479-316	1	-
6	PACKING	Graphite	Graphite	Graphite	1	Set
7	PACKING GLAND	A576-1020 + Cr	A479-410	A479-316	1	-
8	GLAND FLANGE	A105 or A576-1020 (S20C)	A105 or A576-1020 (S20C)	A351-CF8	1	-
9	GLAND BOLT	A193-B7	A193-B7	A193-B8	2/4	-
10	NUT	A194-2H	A194-2H	A194-8	2/4	-
11	BUSH BEARING	A479-304 + Nitr.	A479-316 + Nitr.	A479-316 + HCr. Plating	1	Note 1
12	KEY	A479-410	A479-410	A564-630	1	-
13	SEAL RING	316 SS + Graphite	316 SS + Graphite	316 SS + Graphite	1	Laminated
14	TAPER PIN	410 SS	410 SS	A564-630	1	-
15	YOKE	A576-1020 (S20C)	A576-1020 (S20C)	A576-1020 + Zn. Plating	1	-
16	YOKE BOLT	A193-B7	A193-B7	A193-B8	-	-
17	YOKE NUT	A194-2H	A194-2H	A194-8	-	-
18	MOUNTING BOLT	A193-B7 or EQ.	A193-B7 or EQ.	A193-B7 or EQ.	-	-
19	SPRING WASHER	Steel	Steel	304 SS	-	-
20	KEY	A576-1045	A576-1045	A576-1045	-	-
21	GEAR BOX	Ductile	Ductile	Ductile	1	-
22	CAP	A576-1020 (S20C)	A240-304	A240-316	1	-
23	GASKET (CAP)	304 SS + Graphite	304 SS + Graphite	304 SS + Graphite	1	Spiral wound
24	THRUST BUSH	A479-410	A479-410	A479-316	-	-
25	SEAT RETAINER	A576-1020 + ENP	A240-304	A240-316	-	-
26	RETAINER BOLT	A193-B8	A193-B8	A193-B8M	-	-
27	BUSH BEARING	A479-304 + Nitr.	A479-304 + Nitr.	A479-316 + HCr. Plating	1	Note 1
28	GASKET	304 SS + Graphite	304 SS + Graphite	304 SS + Graphite	1	Spiral wound
29	HANDWHEEL	A53	A53	A53	1	-
30	CAP BOLT	A193-B7	A193-B16	A193-B8	4/8	-
31	CAP NUT	A194-2H	A194-4	A194-8	4/8	-
32	SEAL RING PIN	A479-304	A479-304	A479-316	1	-
33	SPACER	A479-304	A479-304	A479-316	1	-
2	SEAT SURFACE	Stellite No. 6 Faced	Stellite No. 6 Faced	Stellite No. 6 Faced	1	-
13	SEAL RING	Duplex SS + GRAPHITE	Duplex SS + GRAPHITE	Duplex SS + GRAPHITE	1	Laminated
34	LANTERN RING	A564-630 or 316 SS + Nitr.	A564-630 or 316 SS + Nitr.	A564-630 or 316 SS + Nitr.	1	Solid Metal Ring
35	PLUG	A105	410 SS	318 SS	1	-
	GREASE FITTING	Carbon Steel + Cr. Plating	316 SS	316 SS	1	-
36	DRAIN PLUG	A105	410 SS	316 SS	1	-

NOTES: 1. Hardened by Nitriding: Hard Cr. Plating. ENP: Electroless Nickel Plating.

2. Class 150 & 300: 316 Faced Integral, Class 600 & Over, Stellite No. 6 Faced.

3. Recommended Spare Parts: Parts No. 6, 13, 23 & 28

WAFER ENDS BUTTERFLY VALVE

- Cast Steel Butterfly Valve,
- Wafer Ends, Metal Seating
- Designed to ASME B16.34

Face to Face	API 609 (Wafer)
End Flange	ASME B16.5
Wafer Ends	API 609 /MSS-SP-68 ISO 5752
Class	ASME CL150~CL600

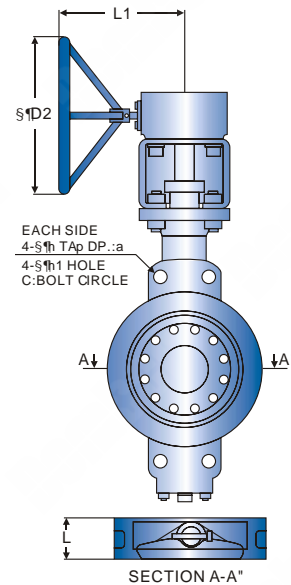
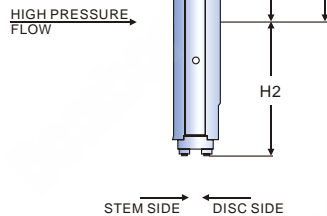
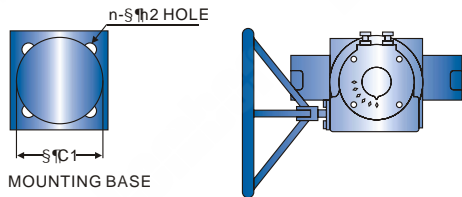

CLASS 150 DIMENSIONS

SIZE (in.)	L	C	FLANGE DIMENSION		h1	H	H1	H2	D2	L1	MOUNTING BASE			W.T (kg) Unit: mm	
			h	a							TYPE	C1	n		h2
3	48	152.4	-	-	19.1	282	258	142	200	165	F07	70	4	9	21
4	54	190.5	-	-	19.1	294	270	162	200	165	F07	70	4	9	27
5	57	215.9	-	-	22.2	319	295	170	200	165	F07	70	4	9	32
6	57	241.3	-	-	22.2	340	316	179	200	165	F07	70	4	9	35
8	64	298.4	-	-	22.2	384	344	208	300	270	F10	102	4	11	53
10	71	361.9	-	-	25.4	434	394	241	300	270	F10	102	4	11	74
12	81	431.8	-	-	25.4	520	470	267	400	335	F14	140	4	18	95
14	92	476.3	-	-	28.6	544	494	316	400	335	F14	140	4	18	131
16	102	539.7	-	-	28.6	643	578	349	500	375	F16	165	4	22	165
18	114	577.8	-	-	31.8	660	595	381	500	375	F16	165	4	22	230
20	127	635.0	1-1/8-8	28.6	-	695	630	412	500	375	F16	165	4	22	280
24	154	749.3	1-1/4-8	31.8	-	813	743	473	600	485	F25	254	8	18	450

CLASS 300 DIMENSIONS

SIZE (in.)	L	C	FLANGE DIMENSION		h1	H	H1	H2	D2	L1	MOUNTING BASE			W.T (Kg) Unit: mm	
			h	a							TYPE	C1	n		h2
3	48	168.2	-	-	22.2	282	258	142	200	165	F07	70	4	9	21
4	54	200.0	-	-	22.2	294	270	162	200	165	F07	70	4	9	27
5	59	234.9	-	-	22.2	319	295	170	300	270	F10	102	4	11	38
6	59	169.8	-	-	22.2	375	336	199	300	270	F10	102	4	11	45
8	73	330.2	-	-	25.4	450	400	227	400	335	F14	140	4	18	72
10	83	387.3	1-8	25.4	-	499	449	265	400	335	F14	140	4	18	135
12	92	450.8	1-1/8-8	28.6	-	562	497	302	500	375	F16	165	4	22	148
14	117	514.3	1-1/8-8	28.6	-	616	551	328	500	375	F16	165	4	22	208
16	133	571.5	1-1/4-8	31.8	-	676	606	367	600	485	F25	254	8	18	298
18	149	628.6	1-1/4-8	31.8	-	711	641	402	600	485	F25	254	8	18	382
20	159	685.8	1-1/4-8	31.8	-	798	721	432	700	520	F30	298	8	22	450
24	181	812.8	1-1/2-8	38.1	-	914	837	530	700	515	F30	298	8	22	680

CLASS 600 DIMENSIONS

SIZE (in.)	L	C	FLANGE DIMENSION		h1	H	H1	H2	D2	L1	MOUNTING BASE			W.T (Kg) Unit: mm	
			h	a							TYPE	C1	n		h2
3	56	168.2	-	-	22.2	289	265	148	200	165	F07	70	4	9	29
4	64	215.9	-	-	25.4	370	330	180	300	270	F10	102	4	11	38
5	78	266.7	-	-	28.6	405	355	195	400	335	F14	140	4	18	55
6	78	292.1	1-8	25.4	-	420	370	225	400	335	F14	140	4	18	75
8	102	349.2	1-1/8-8	28.6	-	490	425	255	500	375	F16	165	4	22	136
10	117	431.9	1-1/4-8	31.8	-	545	480	310	500	375	F16	165	4	22	200
12	140	488.9	1-1/4-8	31.8	-	630	560	330	600	485	F25	254	8	18	295

LUG TYPE BUTTERFLY VALVE

- Cast Steel Butterfly Valve,
- Wafer Lug Type, Metal Seating
- Designed to ASME B16.34

Face to Face	API 609 (Wafer)
End Flange	ASME B16.5
Wafer Ends	API 609 /MSS-SP-68 ISO 5752
Class	ASME CL150~CL600

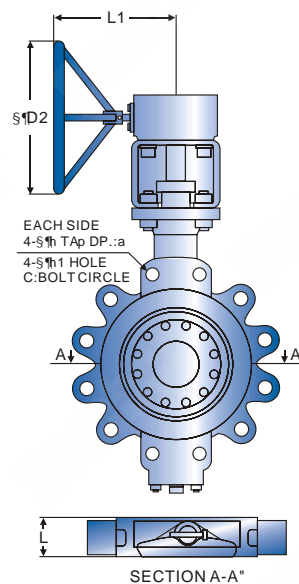
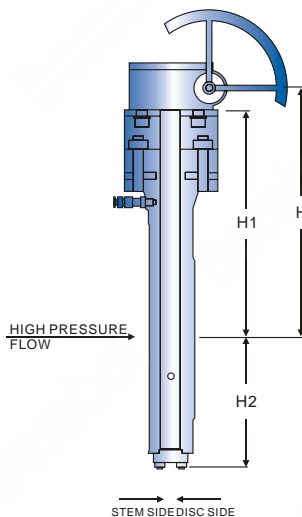
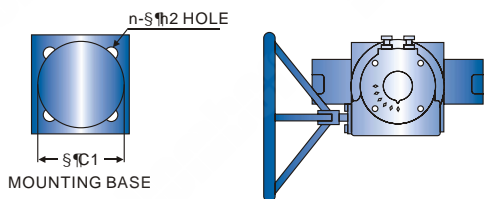

CLASS 150 DIMENSIONS

SIZE (in.)	L	C	FLANGE DIMENSION					H	H1	H2	D2	L1	MOUNTING BASE				W.T(kg) Unit: mm
			h	a	n1	h1	n						TYPE	C1	n	h2	
3	48	152.4	5/8-11	15.8	4	19.1	282	258	142	200	165	F07	70	4	9	23	
4	54	190.5	5/8-11	15.8	8	19.1	294	270	162	200	165	F07	70	4	9	30	
5	57	215.9	3/4-10	19.1	8	22.2	319	295	170	200	165	F07	70	4	9	36	
6	57	241.3	3/4-10	19.1	8	22.2	340	316	179	200	165	F07	70	4	9	39	
8	64	298.4	3/4-10	19.1	8	22.2	384	344	208	300	270	F10	102	4	11	59	
10	71	341.9	7/8-9	22.2	12	25.4	434	394	241	300	270	F10	102	4	11	83	
12	81	431.8	7/8-9	22.2	12	25.4	520	470	267	400	335	F14	140	4	18	110	
14	92	476.3	1-8	25.4	12	28.6	544	494	316	400	335	F14	140	4	18	153	
16	102	539.7	1-8	25.4	16	28.6	643	578	349	500	375	F16	165	4	22	193	
18	114	577.8	1-1/8-8	28.6	16	31.8	660	595	381	500	375	F16	165	4	22	258	
20	127	635.0	1-1/8-8	28.6	20	31.8	695	630	412	500	375	F16	165	4	22	318	
24	154	749.3	1-1/4-8	31.8	20	35.1	813	743	473	600	485	F25	254	8	18	507	

CLASS 300 DIMENSIONS

SIZE (in.)	L	C	FLANGE DIMENSION					H	H1	H2	D2	L1	MOUNTING BASE				W.T(kg) Unit: mm
			h	a	n1	h1	n						TYPE	C1	n	h2	
3	48	168.2	3/4-10	19.1	8	22.2	282	258	142	200	165	F07	70	4	9	24	
4	54	200.0	3/4-10	19.1	8	22.2	294	270	162	200	165	F07	70	4	9	32	
5	59	234.9	3/4-10	19.1	8	22.32	319	295	170	300	270	F10	102	4	11	44	
6	59	269.8	3/4-10	19.1	12	22.2	375	336	199	300	270	F10	102	4	11	52	
8	73	330.2	7/8-9	22.0	12	25.4	450	400	227	400	335	F14	140	4	18	83	
10	83	387.3	1-8	25.4	16	28.6	499	449	265	400	335	F14	140	4	18	151	
12	92	450.8	1-1/8-8	28.6	16	31.8	562	497	302	500	375	F16	165	4	22	172	
14	117	514.3	1-1/8-8	28.6	20	31.8	616	551	328	500	375	F16	165	4	22	249	
16	133	571.5	1-1/4-8	31.8	20	35.1	616	606	367	600	375	F25	254	8	18	352	
18	149	628.6	1-1/4-8	31.8	24	35.1	711	641	402	600	485	F25	254	8	18	449	
20	159	685.8	1-1/4-8	31.8	24	35.1	798	721	432	700	520	F30	298	8	22	534	
24	181	812.8	1-1/2-8	38.1	24	41.2	914	837	530	700	515	F30	298	8	22	812	

CLASS 600 DIMENSIONS

SIZE (in.)	L	C	FLANGE DIMENSION					H	H1	H2	D2	L1	MOUNTING BASE				W.T(kg) Unit: mm
			h	a	n1	h1	n						TYPE	C1	n	h2	
3	54	168.2	3/4-10	19.1	4	22.2	282	265	148	200	165	F07	70	4	9	32	
4	64	215.9	7/8-9	22.2	4	25.4	370	330	180	300	270	F10	102	4	11	45	
5	78	266.7	1-8	25.4	4	28.6	405	355	195	400	335	F14	140	4	18	67	
6	78	292.1	1-8	25.4	8	28.6	420	370	225	400	335	F14	140	4	18	88	
8	102	349.2	1-1/8-8	28.6	8	31.8	490	425	255	500	375	F16	165	4	22	157	
10	117	431.8	1-1/4-8	31.8	12	35.1	545	480	310	500	375	F16	165	4	22	237	
12	140	488.9	1-1/4-8	31.8	16	35.1	630	560	330	600	485	F25	254	8	18	335	

FLANGED (SHORT) ENDS BUTTERFLY VALVE

- Cast Steel Butterfly Valve,
- Double Flanged Ends, Metal Seating
- Designed to ASME B16.34

Face to Face	ISO 5752 (Short)
End Flange	ASME B16.5
Wafer Ends	ISO 5752 Table 4 BS 5155 Table 6 (Long)
Class	ASME CL150-CL600

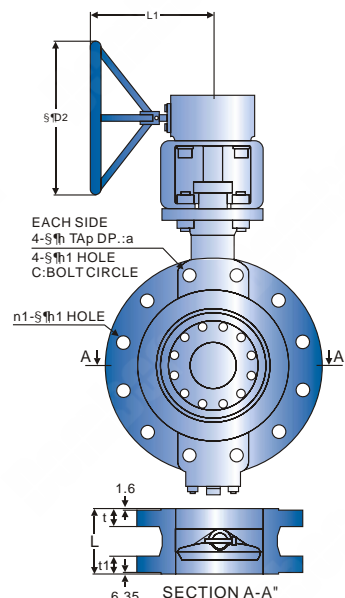
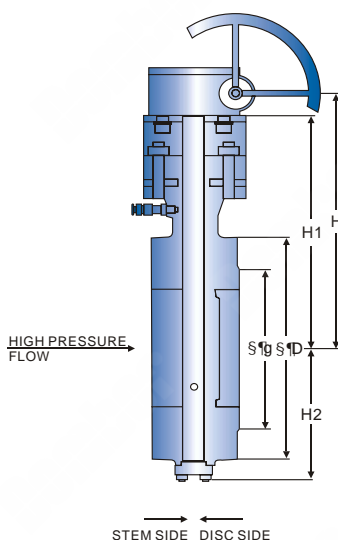
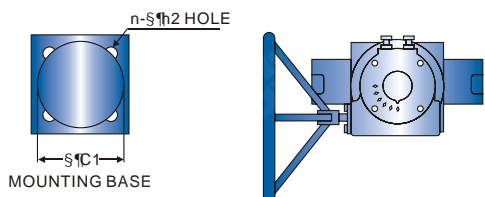

CLASS 150 DIMENSIONS

SIZE (in.)	L	D	g	FLANGE DIMENSION				a	n1	h1	H	H1	H2	D2	L1	MOUNTING BASE			W.T(kg) Unit: mm
				C	t	h	TYPE									C1	n	h2	
3	114	191	127.0	152.4	19.1	5/8-11	15.8	4	19.1	282	258	142	200	165	F07	70	4	9	27
4	127	229	157.2	190.5	24.0	5/8-11	15.8	8	19.1	294	270	162	200	165	F07	70	4	9	35
5	140	254	185.7	215.9	24.0	3/4-10	19.1	8	22.2	319	295	170	200	165	F07	70	4	9	41
6	140	279	215.9	241.3	25.4	3/4-10	19.1	8	22.2	340	316	179	200	165	F07	70	4	9	45
8	152	343	269.7	298.4	28.5	3/4-10	19.1	8	22.2	384	344	208	300	270	F10	102	4	11	68
10	165	406	323.9	361.9	30.3	7/8-9	22.2	12	25.4	434	394	241	300	270	F10	102	4	11	97
12	178	483	381.0	431.8	31.8	7/8-9	22.2	12	25.4	520	470	267	400	335	F14	140	4	18	133
14	190	533	412.8	476.3	35.1	1-8	25.4	12	28.6	544	494	316	400	335	F14	140	4	18	188
16	216	597	469.9	539.7	36.6	1-8	25.4	16	28.6	643	578	349	500	375	F16	165	4	22	238
18	222	635	533.4	577.8	39.7	1-1/8-8	28.6	16	31.8	660	595	381	500	375	F16	165	4	22	302
20	229	699	584.2	635.0	43.0	1-1/8-8	28.6	20	31.8	695	630	412	500	375	F16	165	4	22	380
24	267	813	692.2	749.3	47.8	1-1/4-8	31.8	20	35.1	813	743	473	600	485	F25	254	8	18	599

CLASS 300 DIMENSIONS

SIZE (in.)	L	D	g	FLANGE DIMENSION				a	n1	h1	H	H1	H2	D2	L1	MOUNTING BASE			W.T(kg) Unit: mm
				C	t	h	TYPE									C1	n	h2	
3	114	210	127.0	168.2	28.5	3/4-10	19.1	8	22.2	282	258	142	200	165	F07	70	4	9	29
4	127	254	157.2	200.0	31.8	3/4-10	19.1	8	22.2	294	270	162	200	165	F07	70	4	9	39
5	140	279	185.7	234.9	35.0	3/4-10	19.1	8	22.2	319	295	170	300	270	F10	102	4	11	52
6	140	318	215.9	269.8	36.0	3/4-10	19.1	12	22.2	375	336	199	300	270	F10	102	4	11	63
8	152	381	269.7	330.2	41.2	7/8-9	22.2	12	25.4	450	400	227	400	335	F14	140	4	18	101
10	165	445	323.9	387.3	47.8	1-8	25.4	16	28.6	499	449	265	400	335	F14	140	4	18	176
12	178	521	381.0	450.8	50.8	1-1/8-8	28.6	16	31.8	562	497	302	500	375	F16	165	4	22	210
14	190	584	412.8	514.3	53.9	1-1/8-8	28.6	20	31.8	616	551	328	500	375	F16	165	4	22	315
16	216	648	469.9	571.5	57.2	1-1/4-8	31.8	20	35.1	676	606	367	600	485	F25	254	8	18	440
18	222	711	533.4	628.6	60.5	1-1/4-8	31.8	24	35.1	711	641	402	600	485	F25	254	8	18	558
20	229	775	584.2	685.8	63.5	1-1/4-8	31.8	24	35.1	798	721	432	700	520	F30	298	8	22	670
24	267	814	692.2	812.8	69.9	1-1/2-8	38.1	24	41.2	914	837	530	700	515	F30	298	8	22	1025

CLASS 300 DIMENSIONS

SIZE (in.)	L	D	g	FLANGE DIMENSION				a	n1	h1	H	H1	H2	D2	L1	MOUNTING BASE			W.T(kg) Unit: mm
				C	t	h	TYPE									C1	n	h2	
3	180	210	127.0	168.2	31.8	3/4-10	19.1	8	22.2	289	265	148	200	165	F07	70	4	9	37
4	190	273	157.2	215.9	38.1	7/8-9	22.2	8	25.4	370	330	180	300	270	F10	102	4	11	55
5	200	330	185.7	266.7	44.5	1-8	25.4	12	28.6	405	355	195	400	335	F14	140	4	18	86
6	210	356	215.9	292.1	47.8	1-8	25.4	12	28.6	420	370	225	400	335	F14	140	4	18	109
8	230	419	269.7	349.2	55.7	1-1/8-8	28.6	12	31.8	490	425	255	500	375	F16	165	4	22	192
10	250	508	323.9	431.8	63.5	1-1/4-8	31.8	16	35.1	545	480	310	500	375	F16	165	4	22	296
12	270	559	381.0	488.9	66.6	1-1/4-8	31.5	20	35.1	630	560	330	600	485	F25	254	8	18	390

TECHNICAL DATA

PRESSURE/TEMPERATURE RATING (REF. ASME B16.34)

MAXIMUM WORKING PRESSURE, kgf/cm²A

TEMPERATURE (i) (°)	CLASS 150			CLASS 300			CLASS 600		
	WCB	CF8M	WC9	WCB	CF8M	WC9	WCB	CF8M	WC9
-29to38	20.0	19.3	20.4	52.0	50.6	52.7	104.1	101.2	105.5
93	18.3	16.9	18.3	47.5	43.6	50.3	94.9	87.2	100.5
149	16.2	15.1	16.2	46.1	39.4	47.5	92.5	78.8	95.3
204	14.1	13.7	14.1	44.7	36.2	45.7	89.3	72.4	91.1
260	12.0	12.0	12.0	42.2	33.8	45.0	84.4	67.1	90.0
316	9.8	9.8	9.8	38.7	31.6	42.5	77.0	63.6	85.1
343	8.8	8.8	8.8	37.6	31.3	41.5	75.6	62.6	82.6
371	7.7	7.7	7.7	37.6	30.3	40.1	74.9	60.8	79.8
399	6.7	6.7	6.7	35.5	29.9	37.3	71.0	59.4	74.9
427	5.6	5.6	5.6	28.8	29.2	35.9	58.0	58.4	71.4
454	4.6	4.6	4.6	19.0	28.5	34.1	37.6	57.0	68.6
482	3.5	3.5	3.5	12.0	27.8	31.6	24.3	55.5	53.1
510	2.5	2.5	2.5	7.4	27.1	26.7	14.4	54.5	37.6
538	1.4	1.4	1.4	3.5	25.7	19.0	7.4	51.0	28.1
566		1.4(1)	1.4(1)		25.3	14.1		50.6	15.8
593		1.4(1)	1.4(1)		22.9	8.1		45.4	14.4
624		1.4(1)	1.4(1)		19.3	7.4		38.7	11.0
649		1.4(1)	1.4(1)		14.4	3.9		28.8	

NOTE:

(1) For weld valve only, the temperature rating of flanged end terminates at 538 °C

FLOW DATA

Valve flow coefficient Cv is defined as the flow of water at 60° F in gallons per minute (GPM) at a pressure of one pound per square inch (1 psi) across the valve.

$$Q = C_v \sqrt{(\Delta P (62.4 / \rho))}$$

WHERE

Q = Flow rate (GPM)

Cv = Flow coefficient

ΔP = Pressure drop (psi)

ρ = Density of fluid (ρ = 62.4, water at 60° F)

THEREFORE

$$Q = C_v \sqrt{\Delta P}$$

FLOW COEFFICIENT VALUE (Cv)

CLASS	3"	4"	5"	6"	8"	10"	12"	14"	16"	18"	20"	24"
150#	195	345	500	827	1523	2698	4032	5674	7880	10594	13292	19604
300#	195	345	500	786	1447	2563	3830	5390	7486	10064	12627	18624
600#	195	345	475	746	1374	2435	3640					

Unit: mm

TORQUE DATA

MAX. ΔP (kdf/cm ²)	3"	4"	5"	6"	8"	10"	12"	14"	16"	18"	20"	24"
10.5(150PSIG)	2.8	4.9	6.8	11.0	19.3	29.8	51.2	61.7	86.5	143.	181.8	272.5
20.0(285PSIG)	5.4	9.3	13.0	20.8	36.5	56.4	96.8	116.5	163.1	271.0	342.1	510.7
28.1(400PSIG)	7.6	13.0	18.2	29.1	52.3	81.5	134.2	169.3	236.8	386.0	495.1	735.1
42.2(600PSIG)	11.3	19.6	27.3	43.7	78.4	122.1	201.0	253.6	354.5	578.0	741.0	1098.9
52.0(740PSIG)	14.0	24.1	33.6	53.9	96.7	150.5	247.8	312.6	436.8	712.3	913.1	1353.5
104.1(1480PSIG)	36.4	66.2	90.1	144.9	284.6	449.4	642.5					

Unit: mm

The torque shown in the above chart is actuator sizing torque at the maximum differential pressure.

FLOW CHARACTERISTIC CURVE

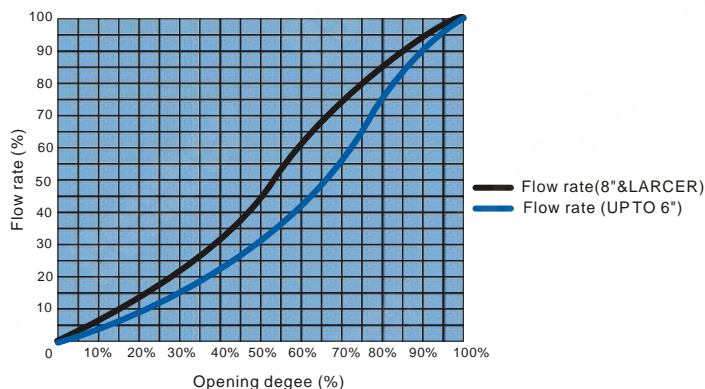

APPLICATION

- Nuclear Power Plants and Power Plants
- Oil Refineries and Chemical Plants
- Pulp and Paper, Steel Mills
- Offshore Plants
- Gas Piping and Local Area Energy Supply System
- Ship Building

SEAT DESIGN PRINCIPLES-HIGH PERFORMANCE

STANDARD DESIGN

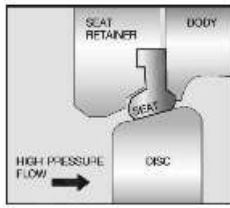

FORWARD FLOW

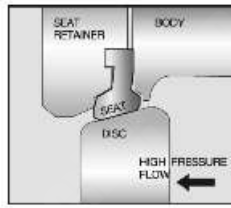

REVERSE FLOW

Bi-directional flow and shut-off are easily accommodated.
As pressure increases, seal becomes tighter.

FIRE SAFE DESIGN

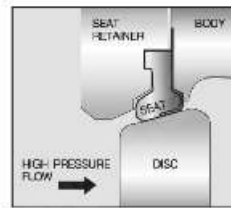

BEFORE FIRE TEST

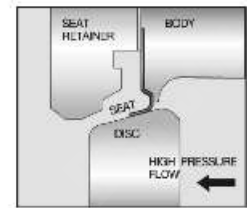

AFTER FIRE TEST

SEAT MATERIAL AND WORKING TEMPERATURE

SEAT MATERIAL	MAX. WORKING TEMPERATURE °C (°F)
PTFE	200 (392)
RTFE	250 (482)

SEAT LEAKAGE

Leakage soft seated version (PTFE, RTFE) is zero.

STANDARD MATERIAL LIST-HIGH PERFORMANCE

NO.	PART NAME	MATERIAL TO ASTM	QTY	REMARK		
1	BODY	A216-WCB	A351-CF8	A351-CF8M	1	Note 3
2	SEAT RING		PTFE, RTFE		1	
3	DISC			A351-CF8M	1	
4	STEM	A351-CF8		A276-316, A564-630	1	
5	RETAINER RING	A267-304, A276-316, A564-630	A276-304		1	
6	PACKING		Graphite, PTFE		1 Set	
7	PACKING GLAND		A276-304		1	
8	GLAND FLANGE		A240-304		1	
9	GLAND BOLT		A193-B8		2/4	
10	SPRING WASHER		304SS		2/4	
11	BUSH BEARING		A276-316 + RTFE		2	Note 3
12	STUFFING RING	A276-304		A276-316	1	
13	DISC PIN		A276-316		1 Set	
14	CAP	A576-1020(S20C)	A240-304	A240-316	1	
15	GASKET		PTFE, RTFE		1	Note 3
16	SEAT RETAINER	A576-1045	A240-304	A240-316	1	
17	RETAINER BOLT	A193-B8		A193-B8M		
18	CAP BOLT		A193-B8			
19	SPRING WASHER		304SS			
20	KEY		A576-1045		1	Note 2
21	GEAR BOX		Ductile		1	
22	HANDWHEEL		A53		1	
2	SEAT RING	PTEE+A240-304, RTFE+A304	PTFE+A240-316	A240-316	1	
3	DISC	A351-CF8+ ENP or HCr.		A351-CFB8M+ENP or HCr.	1	Note 1
		A351-CF8+Stellite No.6	Graphite	A351-CFB8M+Stellite No.6		Faced
6	PACKING		A240-316		1Set	
11	BUSH BEARING		Graphite		1	
15	GASKET					

NOTES: 1. Hcr: Hard Cr. Plating. ENP: Electroless Nickle Plating.

2. PartNo. 20: For 8" & Large Size.

3. RPTFE: Reinforced PTFE.

HIGH PERFORMANCE BUTTERFLY VALVE

- Cast Steel Butterfly Valve,
- Double Flanged Ends, Metal Seating
- Designed to ASME B16.34

Face to Face	ISO 5752 (Short)
End Flange	ASME B16.5
Butt Weld	ISO 5752 Table 4 BS 5155 Table 6 (Long)
Class	ASME CL150~CL600

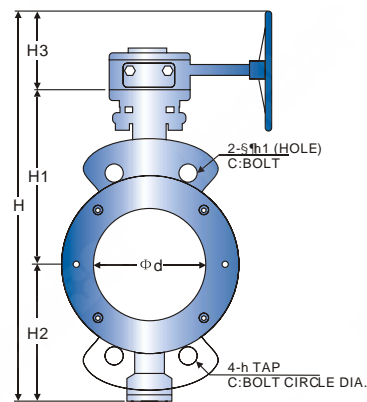
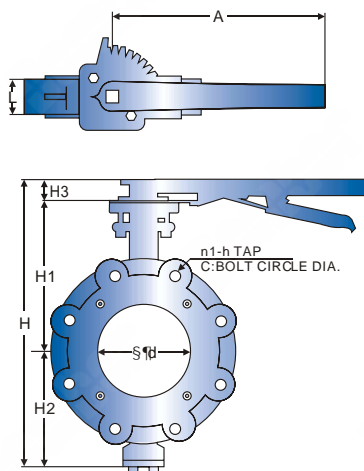
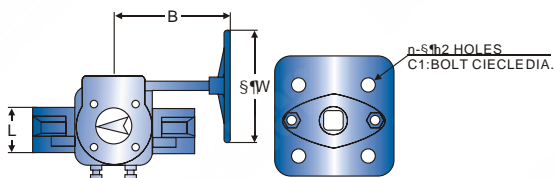

ACTUATOR MOUNTINGBASE

CLASS 150 DIMENSIONS

SIZE (in.)	H	H1	H2	H3	S	L	A	B	S	FLANGE DIMENSION			MOUNTINGBASE				W.T(kg)	
										C	n1	h	h1	n	h2	C1	WAFER	LUG
2"	330	125	100	105	47	43	260	180	150	120.7	4	5/8"x 11unc	19	4	10	83	6.3	6.5
2-1/2"	350	143	102	105	62	46	260	180	150	139.7	4	5/8"x 11unc	19	4	10	83	7.4	11
3"	377	160	112	105	73	48	260	180	150	152.4	4	5/8"x 11unc	19	4	10	83	12	16
4"	406	178	123	105	96	54	330	180	150	190.5	8	5/8"x 11unc	19	4	10	83	20	22
5"	438	193	140	105	119	57	330	180	150	215.9	8	3/4"x 10unc	22.5	4	10	83	24	27
6"	484	213	166	105	138	57	330	180	150	241.3	8	3/4"x 10unc	22.5	4	10	83	26	29
8"	594	235	195	164	187	64	470	260	260	298.5	8	3/4"x 10unc	22.5	4	14	125	32	36
10"	654	270	220	164	235	71	-	260	260	362.0	12	7/8"x 9unc	25.5	4	14	125	51	58
12"	729	300	265	164	274	81	-	260	260	431.8	12	7/8"x 9unc	25.5	4	14	125	72	87
14"	794	330	300	164	316	92	-	260	260	476.3	12	1"x 8unc	28.5	4	14	125	85	98
16"	979	380	345	254	360	102	-	300	400	539.8	16	1"x 8unc	28.5	4	23	165	116	143
18"	1024	400	370	254	418	114	-	300	400	577.9	16	1-1/8"x 8un	-	4	23	165	160	210
20"	1099	435	410	254	468	127	-	300	400	635.0	20	1-1/8"x 8un	-	4	23	165	207	260
22"	1185	470	455	260	510	154	-	350	400	692.2	20	1-1/2"x 8un	-	8	19	192	250	330
24"	1225	490	475	260	548	154	-	350	400	749.3	20	1-1/4"x 8un	-	8	19	192	320	400
26"	1375	570	545	260	607	165	-	350	400	806.5	24	1-1/4"x 8un	-	8	19	192	350	430
28"	1440	600	580	260	654	165	-	350	400	863.6	28	1-1/4"x 8un	-	8	19	192	370	460
30"	1590	625	600	365	698	190	-	390	605	914.4	28	1-1/4"x 8un	-	8	19	254	465	520
32"	1625	645	615	365	755	190	-	390	605	977.9	28	1-1/2"x 8un	-	8	19	254	490	580
34"	1720	690	665	365	813	203	-	390	605	1028.7	32	1-1/2"x 8un	-	8	19	254	-	-
36"	1780	720	695	365	825	203	-	390	605	1085.9	32	1/2"x 8un	-	8	19	254	750	805
38"	1920	790	765	365	918	203	-	390	605	1149.4	32	1-1/2"x 8un	-	8	19	254	-	-
40"	1940	800	775	365	950	216	-	390	605	1200.2	36	1-1/2"x 8un	-	8	19	254	920	1105
42"	2090	875	850	365	1014	241	-	440	605	1257.3	36	1-1/2"x 8un	-	8	23	198	-	-
44"	2100	880	855	365	1040	241	-	440	605	1314.5	40	1-1/2"x 8un	-	8	23	198	1105	1230
46"	2120	890	865	365	1090	254	-	440	605	1365.3	40	1-1/2"x 8un	-	8	23	198	-	-
48"	2180	925	890	365	1162	254	-	440	605	1422.4	44	1-1/2"x 8un	-	8	23	198	1250	1320

CLASS 300 DIMENSIONS

SIZE (in.)	H	H1	H2	H3	S	L	A	B	S	FLANGE DIMENSION			MOUNTINGBASE				W.T(kg)	
										C	n1	h	h1	n	h2	C1	WAFER	LUG
2"	330	125	100	105	47	43	260	180	150	27.0	8	5/8"x 11unc	19	4	10	83	6.3	7
2-1/2"	350	143	102	105	62	46	260	180	150	149.4	8	3/4"x 10unc	22.5	4	10	83	7.4	11
3"	377	160	112	105	73	48	260	180	150	168.1	8	3/4"x 10unc	22.5	4	10	83	12	16
4"	406	178	123	105	96	54	330	180	150	200.2	8	3/4"x 10unc	22.5	4	10	83	20	22
5"	438	193	140	105	119	57	330	180	150	235.0	8	3/4"x 10unc	22.5	4	10	83	24	27
6"	510	220	185	105	138	59	330	180	150	269.7	12	3/4"x 10unc	22.5	4	10	83	27	37
8"	639	260	215	164	187	73	-	260	260	330.2	12	7/8"x 9unc	25.5	4	14	125	45	63

CLASS 300 DIMENSIONS

SIZE (in.)	H	H1	H2	H3	d	L	A	B	FLANGE DIMENSION				MOUNTINGBASE			W.T(kg)		
									W	C	n1	h	h1	n	h2	C1	WAFER	LUG
10"	678	280	234	164	235	83	-	260	260	387.4	16	1"x 8unc	-	4	14	125	67	103
12"	749	320	265	164	274	92	-	260	260	450.9	16	1-1/8"x 8un	-	4	14	125	85	112
14"	929	360	315	254	316	117	-	300	400	514.4	20	1-1/8"x 8un	-	4	23	165	105	220
16"	1069	420	395	254	360	133	-	300	400	571.5	20	1-1/4"x 8un	-	4	23	165	180	280
18"	1120	440	420	260	418	149	-	350	400	628.7	24	1-1/4"x 8un	-	8	19	192	270	360
20"	1185	480	445	260	468	159	-	350	400	685.8	24	1-1/4"x 8un	-	8	19	192	320	450
22"	1355	510	480	365	510	181	-	390	605	743.0	24	1-1/2"x 8un	-	8	19	254	370	620
24"	1435	550	520	365	548	181	-	390	605	812.8	24	1-1/2"x 8un	-	8	19	254	410	700
26"	1505	600	540	365	607	210	-	390	605	876.3	28	1-5/8"x 8un	-	8	19	254	480	810
28"	1565	620	580	365	654	229	-	440	605	939.8	28	1-5/8"x 8un	-	8	19	254	540	960
30"	1695	670	660	365	698	230	-	440	605	997.0	28	1-3/4"x 8un	-	8	19	254	610	1110
32"	1730	690	675	365	755	241	-	440	605	1054.1	28	1-7/8"x 8un	-	8	19	254	670	1205
34"	1825	740	720	365	813	241	-	440	605	1104.9	28	1-7/8"x 8un	-	8	23	298	-	-
36"	1925	790	770	365	825	241	-	440	605	1168.4	32	2"x 8un	-	8	23	298	806	1310
38"	2025	840	820	365	918	300	-	440	605	1092.2	32	1-1/2"x 8un	-	8	23	298	-	-
40"	2125	890	870	365	950	300	-	440	605	1155.7	32	1-5/8"x 8un	-	8	23	298	980	1425

CLASS 600 DIMENSIONS

SIZE (in.)	H	H1	H2	H3	d	L	A	B	FLANGE DIMENSION				MOUNTINGBASE			W.T(kg)		
									W	C	n1	h	h1	n	h2	C1	WAFER	LUG
3"	394	165	124	105	74	54	180	150	26:1	168.1	8	3/4"x 10unc	22.5	4	10	83	18	23
4"	504	190	150	164	92	64	260	260	32:1	215.9	8	7/8"x 9unc	25.5	4	14	125	22	30
5"	599	235	200	164	117	78	260	260	32:1	266.7	8	1"x 8unc	28.5	4	14	125	32	51
6"	609	240	205	164	132	78	260	260	32:1	292.1	12	1"x 8unc	-	4	14	125	60	72
8"	789	290	245	254	174	102	300	400	52:1	249.3	12	1-1/8"x 8un	-	4	23	165	98	116
10"	909	345	310	254	224	117	300	400	52:1	431.8	16	1-1/4"x 8un	-	4	23	165	130	195
12"	975	375	340	260	272	140	350	400	66:1	489.0	20	1-1/4"x 8un	-	8	19	192	250	297
14"	1042	412	370	260	314	155	350	400	66:1	527.1	20	1-3/8"x 8un	-	8	19	192	320	410
16"	1107	442	405	260	358	178	350	400	66:1	603.3	20	1-1/2"x 8un	-	8	19	192	370	500
18"	1190	480	450	260	402	200	350	400	66:1	654.1	20	1-5/8"x 8un	-	8	19	192	420	630
20"	1370	520	485	365	442	216	390	605	80:1	723.9	24	1-5/8"x 8un	-	8	19	254	510	720
24"	1545	595	585	365	542	232	390	605	80:1	838.2	24	1-7/8"x 8un	-	8	19	254	640	940

TORQUE VALUE
Cv VALUE
FULL OPEN

SIZE (in.)	MAX. DIFFERENTIAL PRESSURE (kgf / cm ²)						CLASS		
	10.5 (150PSI)	20 (285PSI)	28.1 (400PSI)	42.2 (600PSI)	49.2 (700PSI)	104.1 (1480PSI)	150	300	600
2"	3.1	3.5	4.4	4.6	4.7	-	92	92	-
2-1/2"	3.3	3.8	4.5	4.8	4.9	-	150	150	-
3"	3.5	4.3	4.8	5.3	5.5	11.8	260	260	155
4"	4.6	6.2	7.1	7.9	8.7	21.0	460	460	255
5"	6.2	8.8	9.4	11.0	12.2	27.8	760	760	710
6"	8.2	10.2	12.2	14.3	14.9	37.0	1150	1100	740
8"	14.3	17.3	19.4	22.4	24.5	67.8	2100	1900	1350
10"	20.9	29.1	34.7	40.8	45.6	105.0	3200	3000	2050
12"	29.9	43.8	53.5	64.2	69.1	160.6	4700	4500	2700
14"	44.7	72.2	100.9	126.4	138.7	254.9	5800	5500	3900
16"	63.7	106.0	138.7	168.2	185.1	328.3	8000	7600	5100
18"	86.2	137.7	185.1	218.7	235.5	408.4	10500	9900	5500
20"	130.0	197.3	246.8	291.6	314.1	547.1	14000	13000	7900
22"	161.6	242.2	295.7	358.9	381.4	-	-	-	-
24"	197.3	296.2	358.9	444.1	475.7	948.3	21000	19500	11100
26"	224.3	336.5	413.0	520.5	565.4	-	25000	-	-
28"	255.9	394.6	475.7	646.5	708.7	-	29000	-	-
30"	304.9	448.7	556.2	735.7	807.6	-	33500	-	-
32"	368.1	556.2	-	-	-	-	41000	-	-
34"	430.8	646.5	-	-	-	-	-	-	-
36"	493.5	744.4	-	-	-	-	55000	-	-
38"	565.9	843.3	-	-	-	-	-	-	-
40"	655.7	987.1	-	-	-	-	70000	-	-
42"	717.9	1076.8	-	-	-	-	-	-	-
44"	781.1	1166.5	-	-	-	-	87000	-	-
46"	852.5	1346.0	-	-	-	-	-	-	-
48"	987.1	1480.6	-	-	-	-	104000	-	-

RESILIENT SEATED BUTTERFLY VALVE

- Cast Steel Butterfly Valve, Resilient Seat
- Double Flanged Ends
- Designed to ASME B16.34

Face to Face	ISO 5752 (Short)
End Flange	ASME B16.5
Butt Weld	ISO 5752 Table 4 BS 5155 Table 6 (Long)
Class	ASME CL150

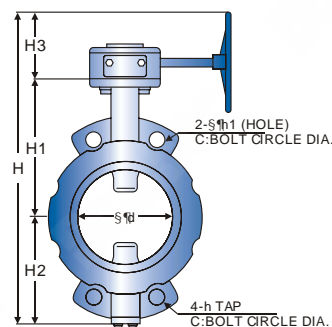
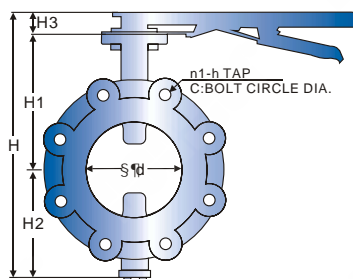

TORQUE VALUE

SIZE (in.)	Cv VALUE MAX. DIFFERENTIAL PRESSURE (kgf/cm ²)			Unit: mm
	5.3 (75 PSI)	105(150 PSI)	FULL OPEN	
2"	2.0	2.5	115	
2-1/2"	2.3	3.1	221	
3"	3.4	4.1	425	
4"	4.8	6.5	792	
5"	7.3	9.0	1290	
6"	11.2	14.6	2175	
8"	14.6	19.1	3984	
10"	29.2	35.9	4900	
12"	43.8	53.8	8710	
14"	57.1	91.8	11460	
16"	78.5	117.3	13702	
18"	123.4	173.3	18302	
20"	157.0	246.8	22903	
22"	208.0	342.6	27479	
24"	241.7	432.3	32096	
26"	314.1	550.6	34944	
28"	403.8	656.7	37791	
30"	471.1	780.1	42988	
32"	527.2	874.9	48185	
34"	605.7	987.1	54543	
36"	683.2	1099.2	60901	
40"	1088.0	1884.4	60901	

ACTUATOR MOUNTING BASE

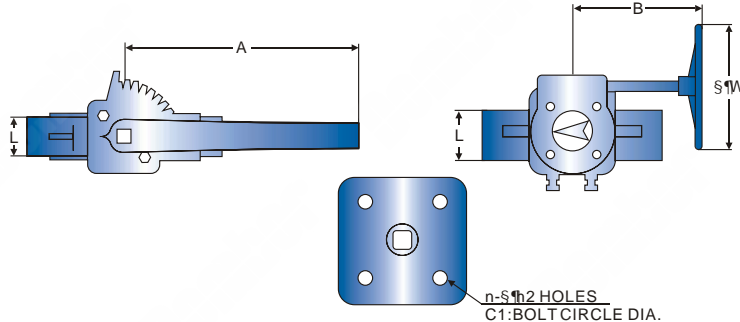

CLASS 150 DIMENSIONS

SIZE (in.)	FLANGE DIMENSION										MOUNTINGBASE				W.T(kg)			
	H	H1	H2	H3	Sφd	L	A	B	SφW	C	n1	h	h1	n	h2	C1	WAFER	LUG
2"	300	130	65	105	50	43	260	180	150	127.7	4	5/8"x 11 unc	19	4	10	83	2.9	3.7
2-1/2"	324	145	74	105	64	46	260	180	150	139.7	4	5/8"x 11 unc	19	4	10	83	4	4.4
3"	343	148	90	105	80	46	260	160	150	152.4	4	5/8"x 11 unc	19	4	10	83	4.8	5.1
4"	390	175	110	105	100	52	330	180	150	190.5	8	5/8"x 11 unc	19	4	10	83	6.8	8.5
5"	418	188	125	105	124	56	330	180	150	215.9	8	3/4"x 10 unc	22.5	4	10	83	8.2	12.1
6"	443	200	138	105	150	56	330	180	150	241.3	8	3/4"x 10 unc	22.5	4	10	83	11.5	13
8"	559	230	165	164	200	60	470	260	260	298.5	8	3/4"x 10 unc	22.5	4	14	125	16	21
10"	629	265	200	164	250	68	-	260	260	362.0	12	7/8"x 9 unc	22.5	4	14	125	22	31
12"	704	305	235	164	300	78	-	260	260	431.8	12	7/8"x 9 unc	22.5	4	14	125	38	46
14"	762	330	268	164	334	78	-	260	260	476.3	12	1"x 8 unc	28.5	4	14	125	50	62
16"	926	310	362	254	390	102	-	300	400	539.8	16	1"x 8 unc	28.5	4	23	165	80	106
18"	981	390	337	254	434	108	-	300	400	577.9	16	1-1/8"x 8 un	-	4	23	165	100	120
20"	1074	440	380	254	486	127	-	300	400	635.0	20	1-1/8"x 8 un	-	4	23	165	142	172
22"	1130	455	415	260	526	154	-	350	400	692.2	20	1-1/4"x 8 un	-	8	19	192	206	252
24"	1182	475	447	260	582	154	-	350	400	749.3	20	1-1/4"x 8 un	-	8	19	192	234	290
26"	1260	525	475	260	622	165	-	350	400	806.5	24	1-1/4"x 8 un	-	8	19	192	262	325
28"	1325	565	500	260	674	165	-	350	400	863.6	28	1-1/4"x 8 un	-	8	19	192	310	385
30"	1505	600	540	365	724	165	-	390	605	914.4	28	1-1/4"x 8 un	-	8	19	254	395	488
32"	1600	620	615	365	774	190	-	390	605	977.9	28	1-1/2"x 8 un	-	8	19	254	470	582
34"	1680	675	640	365	836	200	-	390	605	1028.7	32	1-1/2"x 8 un	-	8	19	254	522	655
36"	1740	705	670	365	872	200	-	390	605	1085.9	32	1-1/2"x 8 un	-	8	19	254	583	725
38"	1805	710	730	365	926	216	-	390	605	1149.4	32	1-1/2"x 8 un	-	8	19	254	-	-
40"	1850	735	750	365	964	216	-	390	605	1200.2	36	1-1/2"x 8 un	-	8	19	254	66	822

BUTTWELD END BUTTERFLY VALVE

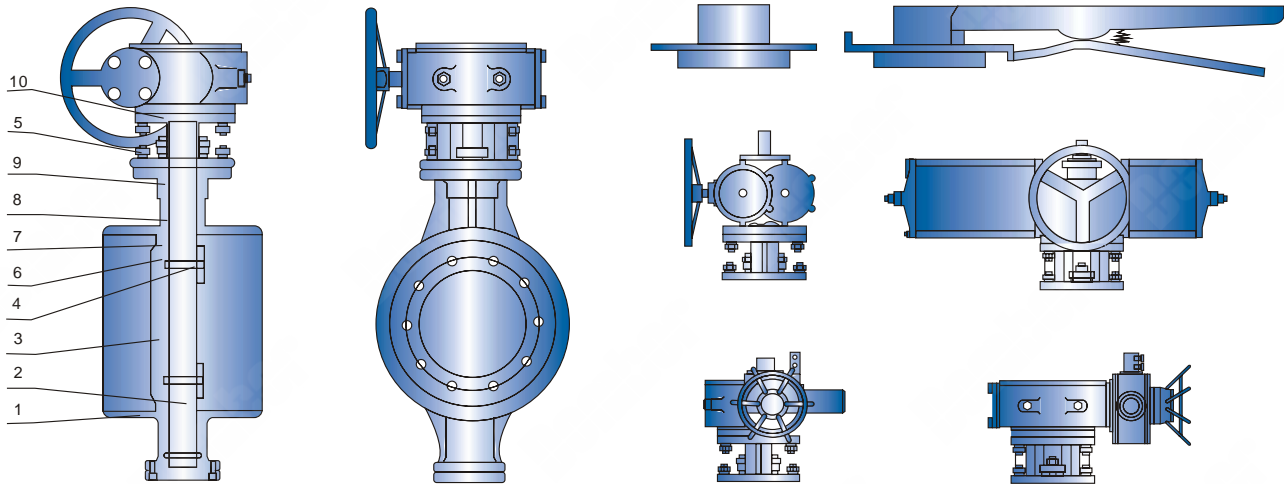

STANDARD MATERIAL SPECIFICATIONS

NO.	Part NAME	ASTM MATERIAL					
		CARBON STEEL	304 TYPE	316 TYPE	304L TYPE	316L TYPE	ALLOY 20
1	Body	A216-WCB	A351-CF8	A351-CF8M	A351-CF3	A351-CF3M	A351-CN7M
2	Stem	A182-F6a	A182-F304	A182-F316	A182-F304L	A182-F316L	Alloy 20
3	Disc	A216-WCB	A351-CF8	A351-CF8M	A351-CF3	A351-CF3M	A351-CN7M
4	Hinge pin	A276-410	A276-304	A276-316	A276-304L	A276-316	Alloy 20
5	Bolt	A193-B7	A193-B8	A193-B8M	A193-B8	A193-B8M	Alloy 20
6	Retaining ring	A105	A182-F304	A182-F316	A182-F304L	A182-F316	Alloy 20
7	Seat ring	Graphite+304	Graphite+304	Graphite+316	Graphite+304L	Graphite+316L	Graphite+Alloy 20
8	Bushing	Bronze	304+PTFE	316+PTFE	304L+PTFE	316L+PTFE	Alloy 20+PTFE
9	Packing	Graphite	PTFE	PTFE	PTFE	PTFE	PTFE
10	Yoke	A216-WCB	A216-WCB	A216-WCB	A216-WCB	A216-WCB	A216-WCB

BUTTWELD END BUTTERFLY VALVE

- Cast Steel Butterfly Valve
- Metal Seat
- Buttwelded Ends
- Designed to ASME B16.34

Face to Face	API 609
End Flange	ASME B16.5
Butt Weld	ISO 5752 Table 4 BS 5155 Table 6 (Long)
Class	ASME CL150

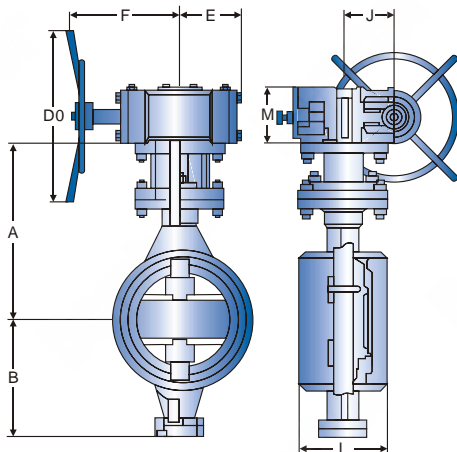

CLASS 150 DIMENSIONS

SIZE (in.)	L	A	B	M	E	F	J	D0	W.T(kg)
3"	114	295	135	115	84	198	84	200	32
4"	127	305	155	115	84	198	84	200	35
5"	140	322	167	115	84	198	84	200	39
6"	140	366	170	115	94	211	84	250	40
8"	152	396	198	134	117	267	145	250	60
10"	165	429	231	134	175	254	145	315	90
12"	178	483	269	159	175	254	145	315	107
14"	190	498	297	159	239	404	145	315	153
16"	216	579	333	163	239	404	145	315	207
18"	222	630	366	163	239	404	191	315	267
20"	229	655	394	163	300	465	191	400	327
24"	267	744	452	185	300	465	191	400	473
28"	292	790	511	185	300	465	191	400	653
30"	308	815	536	220	300	559	269	400	760
32"	318	874	577	220	300	559	269	400	1033
36"	330	899	602	255	300	559	269	400	1200
40"	410	1064	696	255	300	559	269	400	1487
42"	430	1092	721	255	300	559	335	400	1640
44"	450	1148	731	255	300	572	335	400	1800
48"	470	1270	800	320	300	572	335	400	2007
52"	490	1314	850	320	425	635	365	500	2720
56"	530	1384	895	320	425	635	365	500	2980
60"	570	1504	1025	355	425	635	365	500	3387

BUTTWELD END BUTTERFLY VALVE

- Cast Steel Butterfly Valve
- Metal Seat
- Butt welded Ends
- Designed to ASME B16.34

Face to Face	API 609
End Flange	ASME B16.5
Butt Weld	ISO 5752 Table 4 BS 5155 Table 6 (Long)
Class	ASME CL300

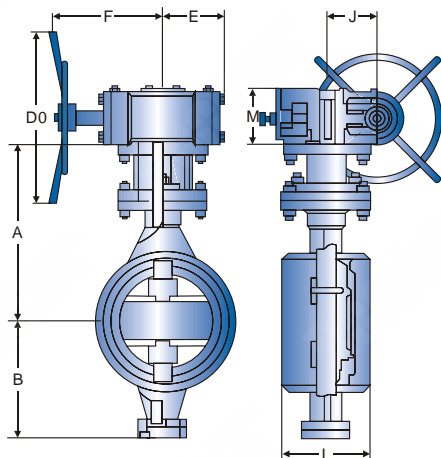

CLASS 300 DIMENSIONS

SIZE (in.)	L	A	B	M	E	F	J	D0	W.T(kg)
									Unit: mm
3"	114	295	132	114	84	198	84	200	34
4"	127	358	150	114	84	198	84	200	44
5"	140	365	167	168	117	267	145	250	58
6"	140	389	188	163	175	254	114	315	73
8"	152	417	22	163	175	254	114	315	132
10"	165	465	1252	185	239	404	145	315	151
12"	178	546	290	185	239	404	145	315	257
14"	190	579	318	221	300	465	191	400	286
16"	216	642	368	221	300	465	191	400	416
18"	222	673	396	221	300	465	191	400	497
20"	229	701	422	254	300	559	269	400	571
24"	267	775	495	254	399	559	269	400	881
28"	292	904	559	305	510	648	351	400	1320
30"	308	963	594	305	510	648	351	400	1478
32"	318	1054	647	305	510	648	429	400	1699
36"	330	1161	676	368	615	805	429	630	2379
40"	410	1242	719	368	615	805	429	630	2427
42"	430	1285	739	368	615	805	429	630	2685
44"	450	1310	764	368	615	805	429	630	2932
48"	470	1374	833	434	765	965	399	630	3545

BUTTWELD END BUTTERFLY VALVE

- Cast Steel Butterfly Valve
- Metal Seat
- Butt welded Ends
- Designed to ASME B16.34

Face to Face	API 609
End Flange	ASME B16.5
Butt Weld	ISO 5752 Table 4 BS 5155 Table 6 (Long)
Class	ASME CL600

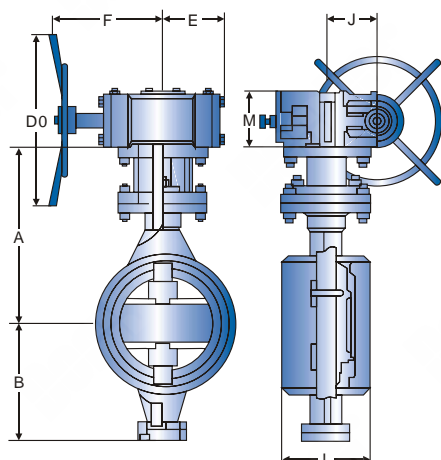

CLASS 600 DIMENSIONS

SIZE (in.)	L	A	B	M	E	F	J	D0	W.T(kg)
									Unit: mm
3"	180	343	127	135	94	211	81	250	75
4"	190	371	160	170	152	267	145	250	117
5"	200	388	178	163	175	254	114	315	154
6"	210	401	196	163	175	254	114	315	186
8"	230	447	221	163	175	254	114	315	235
10"	250	544	290	185	239	404	145	315	398
12"	270	610	307	220	300	465	191	400	554
14"	290	640	330	220	300	465	191	400	654
16"	310	701	391	254	400	559	269	400	935
18"	330	716	406	254	400	559	269	400	85
20"	350	828	452	305	510	645	351	400	610
24"	390	920	513	305	510	645	351	400	998

PRODUCT FEATURES ● RISING STEM BELLOW GLOBE

EXTERNAL STEM THREAD

- Easy to service
- Free from non-ferrous metals

EASILY ACCESSIBLE SAFETY GLAND

- Easy to readjust

BACK SEAT

- Additional stem seal for emergency operation
- Blow-out protection to guard staff and plant
- Stroke limitation protects bellows against overloading

BONNET GASKET INSIDE AND OUTSIDE CONFINED

- Reliable sealing towards the atmosphere

OLIVE-CHROMATED STUDS AND NUTS

- Corrosion-resistant Easy to repair

VALVE SEAT MADE OF CORROSION RESISTANT MATERIALS

- High reliability Long life

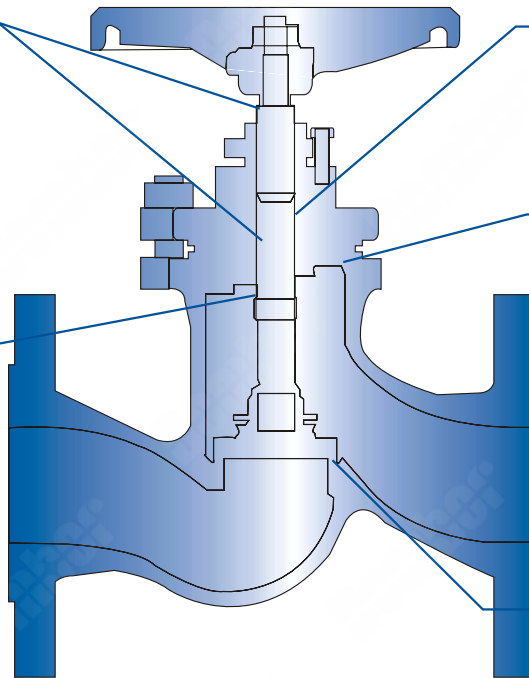

VARIANTS

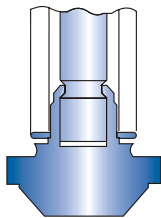

DN 15-50 PN 10-40
DN 65 PN 10/16

THROTTLE CONE

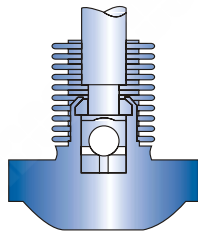

DN 65 PN 25/40
DN 80-100 PN 10-40

POSITION INDICATOR

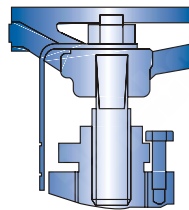

DN 15-100

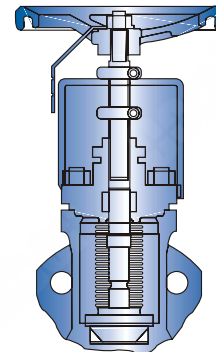

THROTTLE CONE, POSITION INDICATOR, LOCKING DEVICE AND TRAVEL STOP

DIMENSIONS

FACE-TO-FACE DIMENSION - EN 558-1/1

(previously: DIN 3202/F1)
ISO 5752/1

FLANGES

- connecting dimensions to DIN 2501, ISO 2084, BS 4504
- raised-face type C DIN 2526

OTHER FLANGE DESIGNS:

e.g. grooved both ends type N, tongue type F DIN 2512, recessed (female face) type R13, spigot (male face) type V13 DIN 2513, type D, type E DIN 2526; Flanges in acc. with EN 1092/1
Other flange on request.

MAIN COMPONENTS MATERIALS

BODY	BONNET	BELLOW	DISC	NUT	PACKING	GASKET	SEALING FACE	SUITABLE MEDIUM	SUITABLE TEMP.
GS-C25/GS-C25 N/GP240GH/ 1.0619	GS-C25/GS-C25 N/GP240GH/ 1.0619	SS304	Y	YK	Graphite	SS304+ Graphite	13Cr/13Cr 13Cr/STL STL/STL	WATER OIL GAS	≤350°C
1.4308	1.4308	SS304	0Cr18Ni9	0Cr18Ni9	PTFE/ Graphite	SS304+ Graphite/PTFE	304/304 STL/304 STL/STL	Corrosive Media	≤200°C
1.4408	1.4408	SS316L	0Cr18Ni9	0Cr18Ni9	PTFE/ Graphite	SS304+ Graphite/PTFE	316/316 STL/316 STL/STL	Corrosive Media	≤200°C

PRODUCT FEATURES ● NON-RISING STEM BELLOW GLOBE

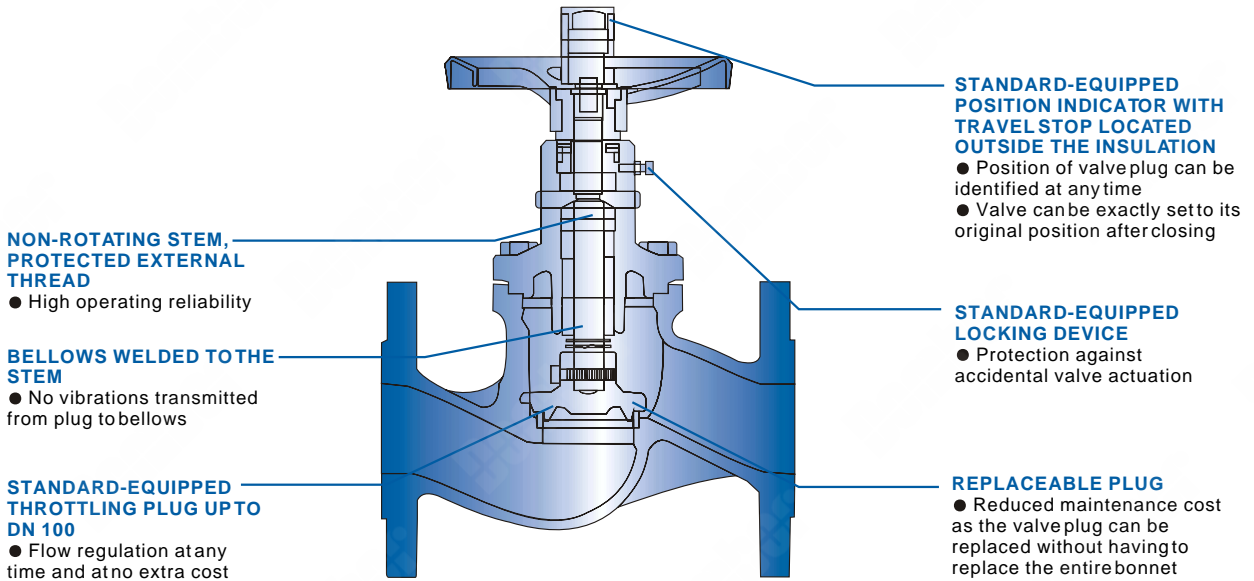

VARIANTS

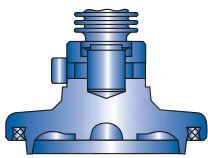

Throttling plug with PTFE seal ring, DN 15-100

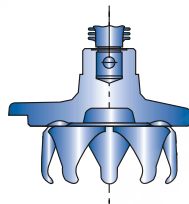

Throttling plug from DN 125

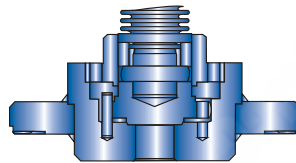

Pilot plug design from DN 200

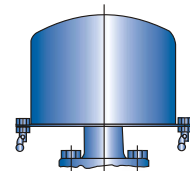

Lead-sealable cap

PRODUCT FEATURES ● NON-RISING STEM BELLOW GLOBE

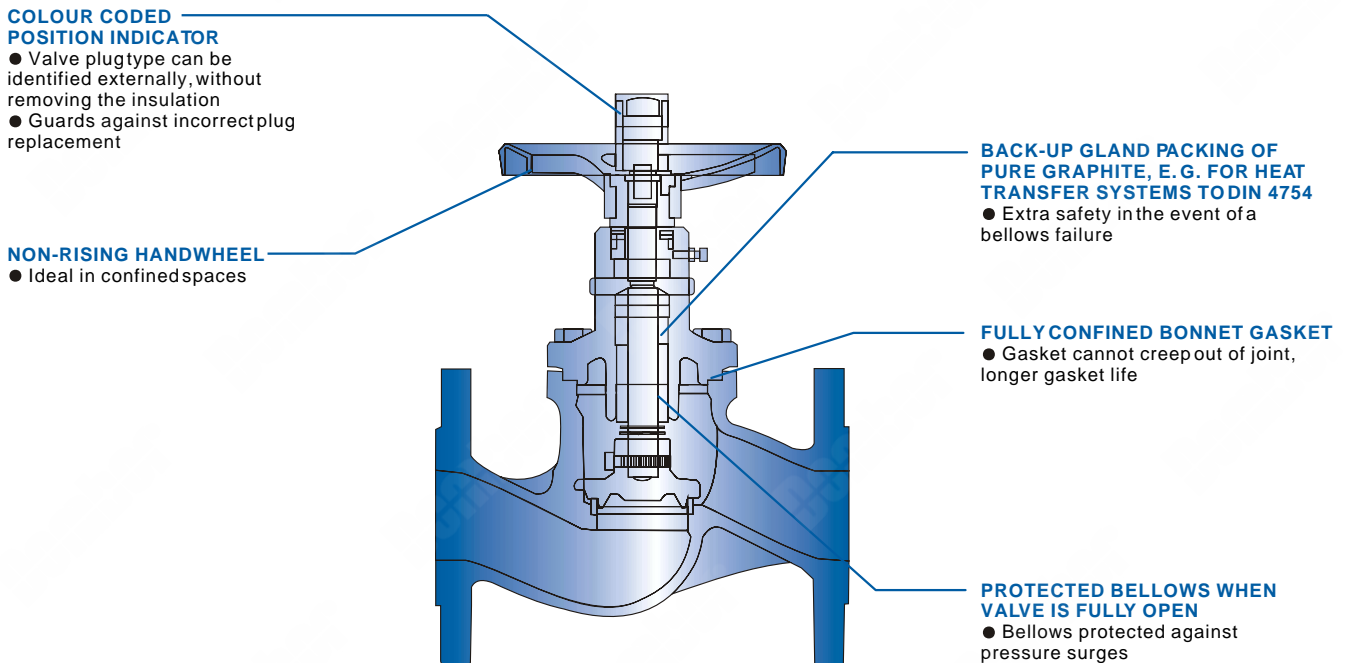

EN/DIN STANDARD NON RISING STEM BELLOW GLOBE VALVE

- Cast Steel Globe Valve, StraightThrough
- Non Rising Stem, Double Bellow Sealed,
- Stem Position Indication
- Designed to EN13709/DIN3356

Face to Face	EN 558-1/DIN 3202 F1
End Flange	EN 1092-1/DIN 2501
Butt Weld	EN 12627
Class	PN16,PN25

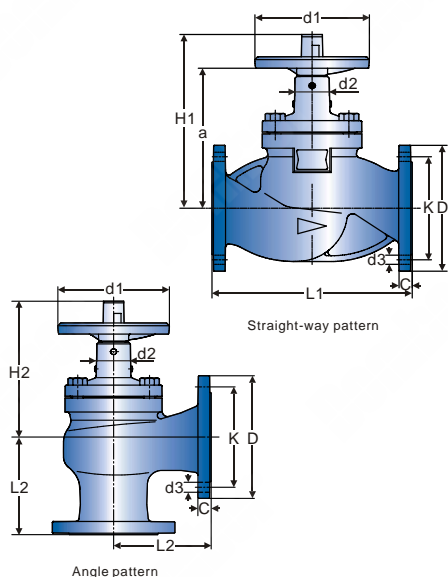

PN16 DIMENSIONS

SIZE (DN)	L1	L2	h1	h2	d1	d2	a	D	k	nxd3	C	W.T(kg) Straight Way Angle Unit: mm	
15	130	90	175	150	125	47	137	95	65	4x14	14	3.1	3.2
20	150	95	178	153	125	47	140	105	75	4x14	16	4.0	4.0
25	160	100	184	151	125	47	146	115	85	4x14	16	4.7	4.8
32	180	105	205	170	125	47	161	140	100	4x19	18	7.3	7.5
40	200	115	210	172	125	47	166	150	110	4x19	18	7.7	7.7
50	230	125	235	198	160	51	190	165	125	4x19	20	10.2	9.6
65	290	145	246	198	160	51	201	185	145	4x19	20	17.0	16.3
80	310	155	282	226	200	60	223	200	160	8x19	22	22.0	21.8
100	350	175	304	244	200	60	245	220	180	8x19	24	32.0	30.8
125	400	200	390	316	250	80	310	250	210	8x19	26	54.0	48.3
150	480	225	408	320	250	80	328	285	240	8x23	26	70.5	65.7
200	600	275	570	468	400	93	440	340	295	12x23	30	130.0	114.2
250	730	325	606	480	400	93	476	405	355	12x23	32	230.0	180.5
300	850	375	660	510	400	93	530	460	410	12x28	32	328.0	267.5

PN25 DIMENSIONS

SIZE (DN)	L1	h1	d1	d2	a	D	k	nxd3	C	W.T(kg) Straight Way Angle Unit: mm	
15	130	175	125	47	137	95	65	4x14	14	3.1	3.1
20	150	178	125	47	140	105	75	4x14	16	4.1	4.1
25	160	184	125	47	146	115	85	4x14	16	4.6	4.6
32	180	205	125	47	161	140	100	4x19	18	8.2	8.2
40	200	210	125	47	166	150	110	4x19	18	8.5	8.5
50	230	235	160	51	190	165	125	4x19	20	11.0	11.0
65	290	246	160	51	201	185	145	8x19	20	17.0	17.0
80	310	282	200	60	223	200	160	8x19	22	28.9	28.9
100	350	304	200	60	245	235	190	8x23	24	40.0	40.0
125	400	390	250	80	310	270	220	8x28	26	65.0	65.0
150	480	408	250	80	328	300	250	8x28	26	89.0	89.0

EN/DIN RISING STEM BELLOW GLOBE VALVE

- Cast Steel Globe Valve, StraightThrough
- Outside Screw and York, Rising Stem,
- Double Bellow Sealed, Stem Position Indication
- Designed to EN13709/DIN3356

Face to Face	EN 558-1/DIN 3202 F1
End Flange	EN 1092-1/DIN 2501
Butt Weld	EN 12627
Class	PN16,PN25,PN40

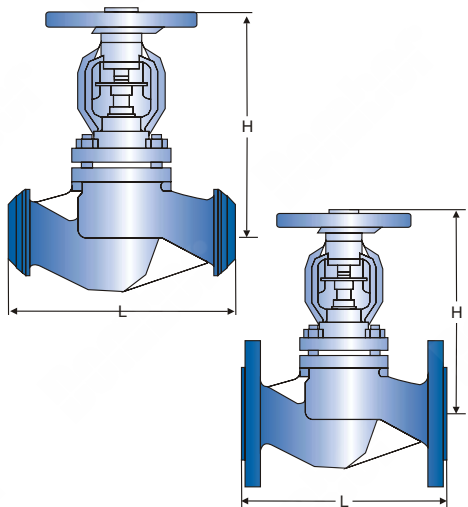

PN16 DIMENSIONS

SIZE (DN)	15	20	25	32	40	50	65	80	100	125	150	200	250	300	350	400
L	130	150	160	180	200	230	290	310	350	400	480	600	730	850	980	1100
H(closed)	196	196	205	205	222	224	240	265	350	380	410	550	715	790	950	1030
STROKE	8	8	10	10	15	16	18	22	28	34	40	60	75	85	100	115
WT FLG (kg)	4.2	4.7	5.6	7.5	9.5	11.9	17.4	23.3	36.0	56.2	78.8	154.0	238.0	339.0	610.0	940.0
B.W (kg)	3.2	3.4	4.0	5.0	6.5	8.0	12.8	18.3	29.6	48.3	68.2	140.5	218.7	312.6	567.0	867.0
KV	4.2	7.4	12.0	19.0	30.0	47.0	77.0	120.0	188.0	288.0	410.0	725.0	1145.0	1635.0	2225	2906

PN25 DIMENSIONS

SIZE (DN)	15	20	25	32	40	50	65	80	100	125	150	200	250	300	350	400
L	130	150	160	180	200	230	290	310	350	400	480	600	730	850	980	1100
H(closed)	196	196	205	205	222	224	240	265	350	380	410	550	715	790	950	1030
Stroke	8	8	10	10	15	16	18	22	28	34	40	60	75	85	100	115
WT FLG (kg)	4.2	4.7	5.6	7.5	9.5	11.9	18.4	25.3	38.2	62.0	86.0	169.0	260.0	370.0	663.0	982.0
B.W (kg)	3.2	3.4	4.0	5.0	6.5	8.0	13.5	19.3	29.8	50.2	70.9	149.5	232.0	332.9	595.0	914.0
KV	4.2	7.4	12.0	19.0	30.0	47.0	77.0	120.0	188.0	288.0	410.0	725.0	1145.0	1635.0	2225	2906

PN40 DIMENSIONS

SIZE (DN)	15	20	25	32	40	50	65	80	100	125	150	200	250	300	350	400
L	130	150	160	180	200	230	290	310	350	400	480	600	730	850	980	1100
H(closed)	196	196	205	205	222	224	240	265	350	380	410	550	715	790	950	1030
Stroke	8	8	10	10	15	16	18	22	28	34	40	60	75	85	100	115
WT FLG (kg)	4.2	4.7	5.6	7.5	9.5	11.9	18.4	26.0	38.7	64.0	87.0	178.0	283.0	398.0	690.0	1039
B.W (kg)	3.2	3.4	4.0	5.0	6.5	8.0	13.7	19.5	30.2	52.1	72.2	152.5	238.0	342.0	623.0	940.0
KV	4.2	7.4	12.0	19.0	30.0	47.0	77.0	120.0	188.0	288.0	410.0	725.0	1145.0	1635.0	2225	2906

EN/DIN ANGLE PATTERN BELLOW GLOBE VALVE

- Cast Steel Globe Valve, Angle Pattern
- Outside Screw and York, Rising Stem
- Double Bellow Sealed, Stem Position Indication
- Designed to EN13709/DIN3356

Face to Face	EN 558-1/DIN 3202 F1
End Flange	EN 1092-1/DIN 2501
Butt Weld	EN 12627
Class	PN16, PN25, PN40

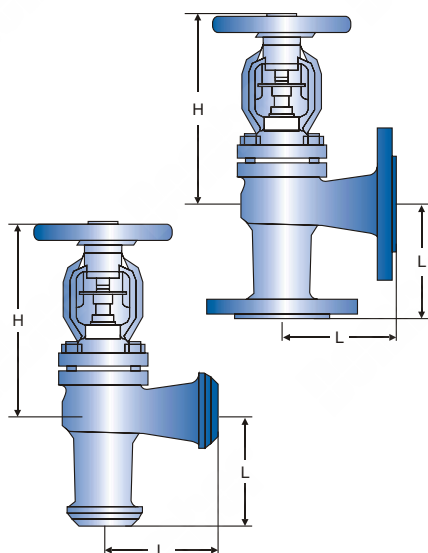

PN16 DIMENSIONS

SIZE (DN)	15	20	25	32	40	50	65	80	100	125	150	200	250	300	350
L	130	95	100	105	115	125	145	155	175	200	225	275	325	375	425
H(closed)	185	189	192	192	205	208	220	245	320	348	360	465	620	675	810
Stroke	8	8	10	10	15	16	18	22	28	34	40	60	75	85	100
WT FLG (kg)	4.3	5.1	6.2	8.1	10.2	12.4	19.4	25.3	37.0	58.2	80.5	157.0	243.0	375.0	620.0
B.W (kg)	3.3	3.7	4.5	5.3	6.9	8.1	14.3	19.6	29.5	48.4	67.8	142.6	223	319	585
KV	4.4	7.48	12.9	19.5	31.4	49.0	81.0	124.0	191.0	295.0	416.0	731.0	1154.0	1648.0	2425

PN25 DIMENSIONS

SIZE (DN)	15	20	25	32	40	50	65	80	100	125	150	200	250	300	350
L	130	95	100	105	115	125	145	155	175	200	225	275	325	375	425
H(closed)	185	189	192	192	205	208	220	245	320	348	360	465	620	675	810
Stroke	8	8	10	10	15	16	18	22	28	34	40	60	75	85	100
WT FLG (kg)	4.3	5.1	6.2	8.1	10.2	12.4	20.0	26.0	40.2	63.0	86.5	168.0	258.0	365.0	655.0
B.W (kg)	3.3	3.7	4.5	5.3	6.9	8.1	14.6	20.0	30.5	49.6	69.0	146.5	230	328	590
KV	4.4	7.48	12.9	19.5	31.4	49.0	81.0	124.0	191.0	295.0	416.0	731.0	1154.0	1648.0	2425

PN40 DIMENSIONS

SIZE (DN)	15	20	25	32	40	50	65	80	100	125	150	200	250	300	350
L	130	95	100	105	115	125	145	155	175	200	225	275	325	375	425
H(closed)	185	189	192	192	205	208	220	245	320	348	360	465	620	675	810
Stroke	8	8	10	10	15	16	18	22	28	34	40	60	75	85	100
WT FLG (kg)	4.3	5.1	6.2	8.1	10.2	12.4	20.3	26.5	41.3	64.3	88.0	173.0	264.0	373.0	670.0
B.W (kg)	3.3	3.7	4.5	5.3	6.9	8.1	14.8	20.2	31.3	50.1	70.3	148.7	234	336	598
KV	4.4	7.48	12.9	19.5	31.4	49.0	81.0	124.0	191.0	295.0	416.0	731.0	1154.0	1648.0	2425

EN/DIN STRAIGHT THROUGH GLOBE VALVE

- Cast Steel Globe Valve, StraightThrough
- Outside Screw and York, Rising Stem
- Designed to EN13709/DIN3356

Face to Face	EN 558-1/DIN 3202 F1
End Flange	EN 1092-1/ DIN 2501
Butt Weld	EN 12627
Class	PN16, PN25, PN40

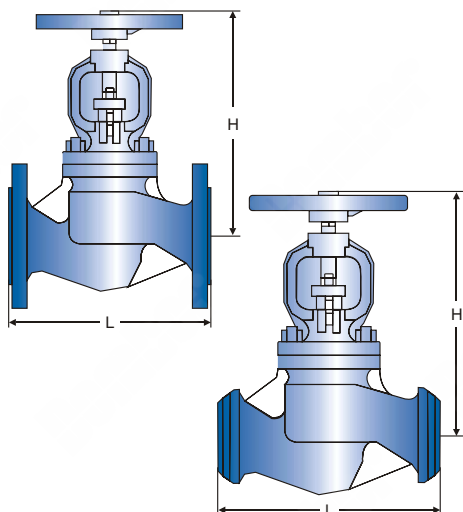

PN16 DIMENSIONS

SIZE (DN)	15	20	25	32	40	50	65	80	100	125	150	200	250	300	350	400
L	130	150	160	180	200	230	290	310	350	400	480	600	730	850	980	1100
H(closed)	180	190	220	220	255	260	265	300	310	390	410	495	660	705	850	950
Stroke	10	12	16	16	20	24	28	30	35	42	50	80	90	110	120	150
WT FLG (kg)	3.6	5.2	6.8	8.5	11.7	16	22.8	31.0	38.4	58.0	82.0	167.0	314.0	430	590.0	954.0
B.W (kg)	2.1	3.8	5.1	5.7	8.4	11.7	17.7	25.3	30.9	49.2	69.5	153.0	294.0	404	555	905
KV	4.6	8.0	13.2	21.0	33.0	51.0	83.0	133.0	205.0	315.0	454.0	780.0	1285.0	1805.0	2225	2906

PN25 DIMENSIONS

SIZE (DN)	15	20	25	32	40	50	65	80	100	125	150	200	250	300	350	400
L	130	150	160	180	200	230	290	310	350	400	480	600	730	850	980	1100
H(closed)	180	190	220	220	255	260	265	300	310	390	410	495	660	705	850	950
Stroke	10	12	16	16	20	24	28	30	35	42	50	80	90	110	120	150
WT FLG (kg)	3.6	5.2	6.8	8.5	11.7	16	23.3	32.6	41.4	62.7	88.6	177.6	329.2	450	624.4	999.2
B.W (kg)	2.1	3.8	5.1	5.7	8.4	11.7	17.7	25.8	31.8	49.7	71.2	155.8	299	410	565.0	919
KV	4.6	8.0	13.2	21.0	33.0	51.0	83.0	133.0	205.0	315.0	454.0	780.0	1285.0	1805.0	2225	2906

PN40 DIMENSIONS

SIZE (DN)	15	20	25	32	40	50	65	80	100	125	150	200	250	300	350	400
L	130	150	160	180	200	230	290	310	350	400	480	600	730	850	980	1100
H(closed)	180	190	220	220	255	260	265	300	310	390	410	495	660	705	850	950
Stroke	10	12	16	16	20	24	28	30	35	42	50	80	90	110	120	150
WT FLG (kg)	3.6	5.2	6.8	8.5	11.7	16	23.6	33.4	42.4	64.2	91.0	186.5	340.0	484.0	672.0	1026.0
B.W (kg)	2.1	3.8	5.1	5.7	8.4	11.7	18.0	26.6	32.8	51.2	74.2	159.4	305	425	565.0	919
KV	4.6	8.0	13.2	21.0	33.0	51.0	83.0	133.0	205.0	315.0	454.0	780.0	1285.0	1805.0	2225	2906

EN/DIN ANGLE PATTERN GLOBE VALVE

- Cast Steel Globe Valve, Angle
- Outside Screw and York, Rising Stem
- Designed to EN13709/DIN3356

Face to Face	EN 558-1/DIN 3202 F1
End Flange	EN 1092-1/DIN 2501
Butt Weld	EN 12627
Class	PN16, PN25, PN40

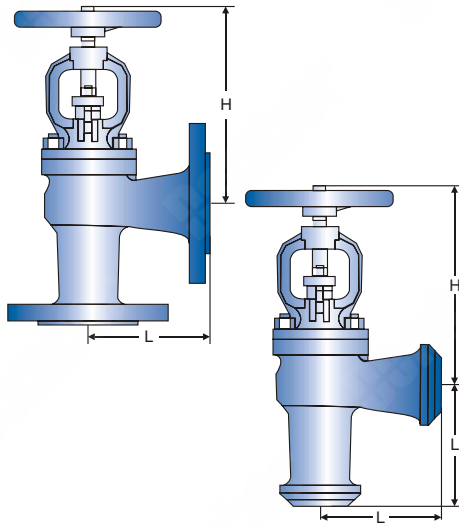

PN16 DIMENSIONS

SIZE (DN)	15	20	25	32	40	50	65	80	100	125	150	200	250	300	350
L	90	95	100	105	115	125	145	155	175	400	225	275	325	375	425
H(closed)	166	175	205	205	227	240	265	300	325	375	400	540	600	600	650
Stroke	10	12	16	16	20	24	28	30	35	42	50	80	90	110	120
W.T FLG (kg)	3.40	5.4	6.7	8.4	10.8	14.6	21.4	28.1	37.8	63.4	88.3	171	320	440	614
B.W (kg)	2.4	4.0	5.0	5.6	7.5	10.4	16.3	22.4	30.3	53.6	75.6	157	300	414	579
KV	4.6	8	13.2	21.0	33.0	51.0	83.0	133.0	205.0	315.0	454.0	780.0	1285.0	1805.0	2425

PN25 DIMENSIONS

SIZE (DN)	15	20	25	32	40	50	65	80	100	125	150	200	250	300	350
L	90	95	100	105	115	125	145	155	175	400	225	275	325	375	425
H(closed)	166	175	205	205	227	240	265	300	325	375	400	540	600	600	650
Stroke	10	12	16	16	20	24	28	30	35	42	50	80	90	110	120
W.T FLG (kg)	3.40	5.4	6.7	8.4	10.8	14.6	21.9	29.0	40.8	68.0	94.7	182.0	335.0	462.0	654
B.W (kg)	2.4	4.0	5.2	5.9	8.1	10.9	16.8	23.0	32.0	55.0	79.0	161.0	305.0	425.0	589
KV	4.6	8	13.2	21.0	33.0	51.0	83.0	133.0	205.0	315.0	454.0	780.0	1285.0	1805.0	2425

PN40 DIMENSIONS

SIZE (DN)	15	20	25	32	40	50	65	80	100	125	150	200	250	300	350
L	90	95	100	105	115	125	145	155	175	400	225	275	325	375	425
H(closed)	166	175	205	205	227	240	265	300	325	375	400	540	600	600	650
Stroke	10	12	16	16	20	24	28	30	35	42	50	80	90	110	120
W.T FLG (kg)	3.40	5.4	6.7	8.4	10.8	14.6	22.4	29.5	41.9	69.3	96.8	192.0	359.0	492.0	689
B.W (kg)	2.5	4.3	5.5	6.3	8.3	11.2	17.3	24.0	33.8	57.2	81.0	166.0	314.0	443.0	602
KV	4.6	8	13.2	21.0	33.0	51.0	83.0	133.0	205.0	315.0	454.0	780.0	1285.0	1805.0	2425

EN/DIN BELLOW GATE VALVE

- Cast Steel Gate Valve, Straight Through
- Outside Screw and York, Rising Stem
- Double Bellow Sealed
- Designed to DIN3352, ASME B16.10, BS1973

Face to Face	EN 558-1/DIN 3202 F4/F5
End Flange	EN 1092
Butt Weld	EN 12627
Class	PN10, PN16

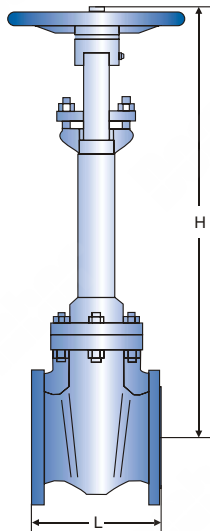

PN10(F4) DIMENSIONS

SIZE (DN)	40	50	65	80	100	125	150	200	250	300	350	400	500	600
L	140	150	170	180	190	200	210	230	250	270	-	-	-	-
H(closed)	400	458	530	615	748	887	1014	1294	1595	1880	-	-	-	-
Stroke	50	60	75	90	110	138	162	212	265	318	368	424	525	628
W.T(kg)	17.2	21.0	24.5	32.5	39.0	54.5	70.5	105.0	147.5	201				
KV	59	90	149	236	360	567	815	1400	2300	3249	4420	5770	9015	12980

PN10(F5) DIMENSIONS

SIZE (DN)	40	50	65	80	100	125	150	200	250	300	350	400	500	600
L	240	250	270	280	300	325	350	400	450	500	550	600	600	800
H(closed)	430	478	575	647	733	897	974	1214	1455	1650	1930	2187	2695	3110
Stroke	50	60	75	90	110	138	162	212	265	318	368	424	525	628
W.T(kg)	23	25.5	35	33.5	59.0	76.5	93.5	164.5	223.0	304.5	382	522	775	1250
KV	59	90	149	236	360	567	815	1400	2300	3249	4420	5770	9015	12980

PN16(F5) DIMENSIONS

SIZE (DN)	40	50	65	80	100	125	150	200	250	300	350	400	500	600
L	240	250	270	280	300	325	350	400	450	500	550	600	600	800
H(closed)	430	478	575	647	733	897	974	1214	1455	1650	1930	2187	2695	3110
Stroke	50	60	75	90	110	138	162	212	265	318	368	424	525	628
W.T(kg)	23	25.5	35	33.5	59.0	76.5	93.5	164.5	223.0	304.5	-	-	-	-
KV	59	90	149	236	360	567	815	1400	2300	3249	4420	5770	9015	12980

EN/DIN GATE VALVE

- Cast Steel Gate Valve, Straight Through
- Outside Screw and York, Rising Stem
- Designed to DIN3352

Face to Face	EN 558-1/DIN 3202 F4/F5
End Flange	EN 1092
Butt Weld	EN 12627
Class	PN10, PN16

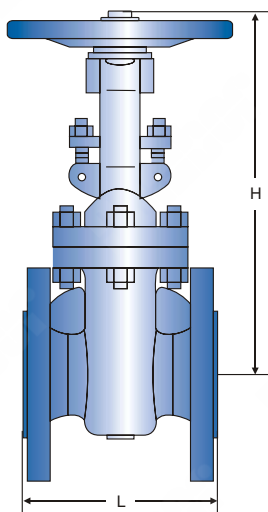

PN10(F4) DIMENSIONS

SIZE (DN)	40	50	65	80	100	125	150	200	250	300	350	400	500	600
L	140	150	170	180	190	200	210	230	250	270	-	-	-	-
H(closed)	260	290	320	360	440	500	560	700	850	990	-	-	-	-
Stroke	50	60	75	90	110	138	162	212	265	318	368	424	525	628
W.T(kg)	13.2	16.0	20.5	28.0	33.0	47.5	62.5	91.0	131.5	176	-	-	-	-
KV	59	90	149	236	360	567	815	1400	2300	3249	4420	5770	9015	12980

PN10(F5) DIMENSIONS

SIZE (DN)	40	50	65	80	100	125	150	200	250	300	350	400	500	600
L	240	250	270	280	300	325	350	400	450	500	550	600	700	800
H(closed)	290	310	365	395	425	480	520	620	710	760	900	1000	1225	1360
Stroke	50	60	75	90	110	138	162	212	265	318	368	424	525	628
W.T(kg)	18	19.5	30	37.5	52.0	68.5	84.5	141.5	201.0	280.5	340	474	724	1166
KV	59	90	149	236	360	567	815	1400	2300	3249	4420	5770	9015	12980

PN16(F5) DIMENSIONS

SIZE (DN)	40	50	65	80	100	125	150	200	250	300	350	400	500	600
L	240	250	270	280	300	325	350	400	450	500	550	600	700	800
H(closed)	290	310	365	395	425	480	520	620	710	760	900	1000	1225	1360
Stroke	50	60	75	90	110	138	162	212	265	318	368	424	525	628
W.T(kg)	18	19.5	30	37.5	52.0	68.5	84.5	141.5	201.0	280.5	-	-	-	-
KV	59	90	149	236	360	567	815	1400	2300	3249	4420	5770	9015	12980

EN/DIN LIFT CHECK VALVE

- Cast Steel Check Valve, Straight Way
- Bolted Cover, Lift Piston
- Designed to EN13709/DIN3356

Face to Face	EN 558-1/DIN 3202 F1
End Flange	EN 1092/DIN 2543
Butt Weld	EN 12627
Class	PN16, PN25, PN40

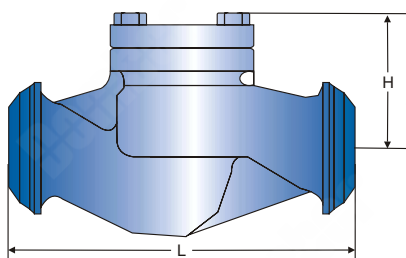
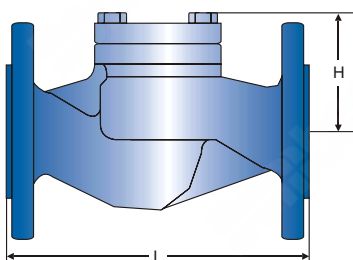

PN16 DIMENSIONS

SIZE (DN)	15	20	25	32	40	50	65	80	100	125	150	200	250	300	350	400
L	130	150	160	180	200	230	290	310	350	400	480	600	730	850	980	1100
H(closed)	60	65	75	78	85	90	105	125	145	173	208	370	460	505	555	635
Stroke	10	10	12	12	18	18	20	25	30	40	50	70	75	80	120	150
W.T FLG (kg)	3.4	3.9	4.6	6.4	8.2	10.8	16.3	22.5	32.0	51.0	74	139	208	308	520	820
B.W (kg)	2.4	2.6	2.9	3.6	4.9	6.5	11.2	16.8	24.5	41.2	61.3	124.6	188.0	282.0	485.0	772
KV	3.9	6.9	11.1	17.6	27.8	43.5	71.3	112	174	267	380	670	1060	1514	2060	2690

PN25 DIMENSIONS

SIZE (DN)	15	20	25	32	40	50	65	80	100	125	150	200	250	300	350	400
L	130	150	160	180	200	230	290	310	350	400	480	600	730	850	980	1100
H(closed)	60	65	75	78	85	90	105	125	145	173	208	370	460	505	555	635
Stroke	10	10	12	12	18	18	20	25	30	40	50	70	75	80	120	150
W.T FLG (kg)	3.4	3.9	4.6	6.4	8.2	10.8	16.9	24.1	35.0	55.7	80.2	149.6	223.2	328	554.4	865.2
(kg) B.W	2.4	2.6	2.9	3.6	4.9	6.5	11.4	17.3	25.4	42.7	63.2	127.8	192.6	287.7	495.0	785.0
KV	3.9	6.9	11.1	17.6	27.8	43.5	71.3	112	174	267	380	670	1060	1514	2060	2690

PN40 DIMENSIONS

SIZE (DN)	15	20	25	32	40	50	65	80	100	125	150	200	250	300	350	400
L	130	150	160	180	200	230	290	310	350	400	480	600	730	850	980	1100
H(closed)	60	65	75	78	85	90	105	125	145	173	208	370	460	505	555	635
Stroke	10	10	12	12	18	18	20	25	30	40	50	70	75	80	120	150
W.T FLG (kg)	3.4	3.9	4.6	6.4	8.2	10.8	16.9	24.1	35.0	55.7	81.2	159.5	244.4	363	595.8	938
(kg) B.W	2.4	2.6	2.9	3.6	4.9	6.5	11.6	17.8	25.9	43.6	63.2	157.5	240.4	356	586.8	927
KV	3.9	6.9	11.1	17.6	27.8	43.5	71.3	112	174	267	380	670	1060	1514	2060	2690

EN/DIN LIFT ANGLE CHECK VALVE

- Cast Steel Check Valve, Angle Pattern
- Bolted Cover, Lift Piston
- Designed to EN13709/DIN3356

Face to Face	EN 558-1/DIN 3202F1
End Flange	EN 1092/DIN 2543
Butt Weld	EN 12627
Class	PN16, PN25, PN40

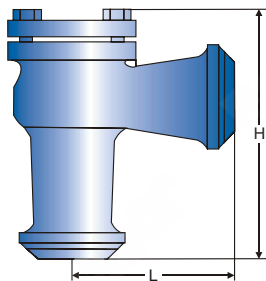
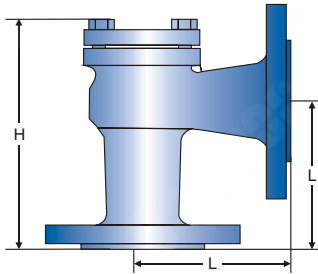

PN16 DIMENSIONS

SIZE (DN)	15	20	25	32	40	50	65	80	100	125	150	200	250	300	350
L	90	95	100	105	115	125	145	155	175	200	225	275	325	375	425
H(closed)	57	63	75	75	80	89	98	115	138	160	240	270	317	340	380
Stroke	10	10	12	12	18	18	20	25	30	40	50	70	75	80	120
W.T FLG (kg)	3.6	4.1	4.9	6.8	8.4	11.3	16.7	23.0	33	52	76	143	211	315	527
B.W (kg)	2.8	3.0	3.6	4.6	5.9	8.0	12.7	18.7	27.6	45.2	66.9	131.4	194.5	292	498
KV	4.2	7.4	12.0	19.0	30.0	47.0	77.0	120.0	188.0	288.0	410.0	725.0	1145.0	1635.0	2225

PN25 DIMENSIONS

SIZE (DN)	15	20	25	32	40	50	65	80	100	125	150	200	250	300	350
L	90	95	100	105	115	125	145	155	175	200	225	275	325	375	425
H(closed)	57	63	75	75	80	89	98	115	138	160	240	270	317	340	380
Stroke	10	10	12	12	18	18	20	25	30	40	50	70	75	80	120
W.T FLG (kg)	3.6	4.1	4.9	6.8	8.4	11.3	17.3	24.6	36.0	56.7	82.2	153.6	228.2	335	561
B.W (kg)	2.8	3.0	3.6	4.6	5.9	8.0	13.2	20.5	31.0	49.2	72.0	140.6	212	311	530
KV	4.2	7.4	12.0	19.0	30.0	47.0	77.0	120.0	188.0	288.0	410.0	725.0	1145.0	1635.0	2225

PN40 DIMENSIONS

SIZE (DN)	15	20	25	32	40	50	65	80	100	125	150	200	250	300	350
L	90	95	100	105	115	125	145	155	175	200	225	275	325	375	425
H(closed)	57	63	75	75	80	89	98	115	138	160	240	270	317	340	380
Stroke	10	10	12	12	18	18	20	25	30	40	50	70	75	80	120
W.T FLG (kg)	3.6	4.1	4.9	6.8	8.4	11.3	17.3	24.6	36.0	58.7	82.2	161.5	245.4	363	594
B.W (kg)	2.8	3.0	3.6	4.6	5.9	8.0	13.5	21.2	32.0	51.0	74.0	148.0	223	340	568
KV	4.2	7.4	12.0	19.0	30.0	47.0	77.0	120.0	188.0	288.0	410.0	725.0	1145.0	1635.0	2225

API/BS BELLOW GLOBE VALVE

- Cast Steel Globe Valve, Straight Through
- Outside Screw and York, Rising Stem,
- Double Bellow Sealed, Stem Position Indication
- Designed to ANSI B16.34, BS1873

Face to Face	ANSI B16.10
End Flange	ANSI B16.5
Butt Weld	ANSI B16.25
Class	ANSI CL150-CL300

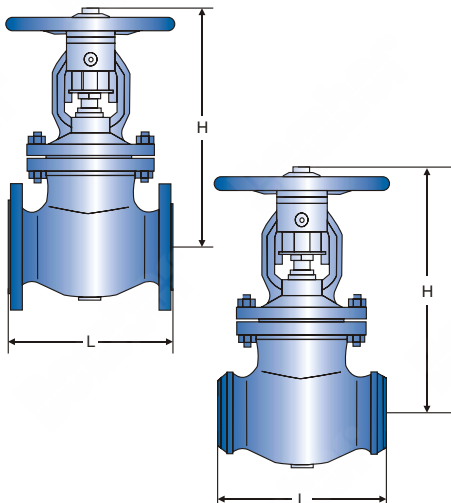

CLASS 150 DIMENSIONS

SIZE (in.)	2"	2.5"	3"	4"	5"	6"	8"	10"	12"
L	FLG 203	216	241	292	356	406	495	622	698
B.W	203	216	318	292	356	406	495	622	698
H(closed) FLG	318	355	395	430	490	545	645	790	930
B.W	318	355	405	430	490	545	645	790	930
Stroke	21	24	30	35	38	48	60	70	85
W.T FLG	18	30	41	64	86	120	200	295	450
(kg) B.W	14.6	26	36	56.5	76	107	183	271	420
KV	47.0	77.0	120.0	188.0	288.0	410.0	725.0	1145.0	1635.0

CLASS 300 DIMENSIONS

SIZE (in.)	2"	2.5"	3"	4"	5"	6"	8"	10"	12"
L	FLG 267	292	318	356	400	444	559	622	711
B.W	267	292	318	356	400	444	559	622	711
H(closed) FLG	325	360	405	446	505	560	675	820	960
B.W	325	360	405	446	505	560	675	820	960
Stroke	21	24	30	35	38	48	60	70	85
W.T FLG	25	34	48	73	103	168	260	460	615
(kg) B.W	21.4	29.5	43	65	92	154	242	434	580
KV	47.0	77.0	120.0	188.0	288.0	410.0	725.0	1145.0	1635.0

API/BS BELLOW GATE VALVE

- Cast Steel Gate Valve
- Outside Screw and York, Rising Stem,
- Double Bellow Sealed, Stem Position Indication
- Designed to API 6D, API 600

Face to Face	ANSI B16.10
End Flange	ANSI B16.5
Butt Weld	ANSI B16.25
Class	ANSI CL150~CL300

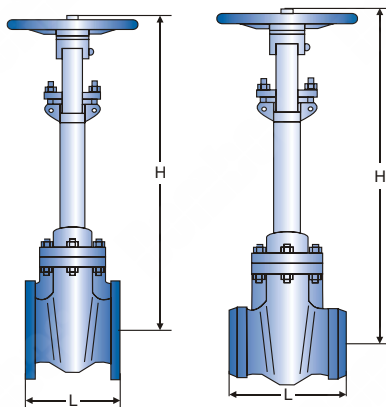

CLASS 150 DIMENSIONS

SIZE (in.)		2"	2.5"	3"	4"	5"	6"	8"	10"	12"
L	FLG	178	190	203	229	254	267	292	330	356
	B.W	216	241	283	305	381	404	419	457	502
H(closed)	FLG	480	500	580	735	790	950	1160	1460	1780
	B.W	480	500	580	735	790	950	1160	1460	1780
Stroke		60	77	93	115	138	165	218	268	320
W.T (kg)	FLG	25.3	35	44	69	72	119	189	290	380
	B.W	22.6	31.5	40	62	64	108	175	270	355
KV		90	149	236	360	567	815	1400	2300	3249

CLASS 300 DIMENSIONS

SIZE (in.)		2"	2.5"	3"	4"	5"	6"	8"	10"	12"
L	FLG	216	241	283	305	381	403	419	457	502
	B.W	216	241	283	305	381	403	419	457	502
H(closed)	FLG	490	550	600	750	890	990	1300	1460	1780
	B.W	490	550	600	750	890	990	1300	1530	1840
Stroke		60	77	93	115	138	165	218	268	320
W.T (kg)	B.W	29.4	36	62	76	108	157	293	425	598
	FLG	33	40	67	84	116	170	310	450	630
KV		90	149	236	360	567	815	1400	2300	3249

EN/DIN FORGED BELLOW GLOBE VALVE

- Forged Steel Globe Valve, Full Port or Reduced Bore
- Outside Screw and York, Rising Stem,
- Double Bellow Sealed, Stem Position Indication
- Designed to EN13709/DIN3356

Face to Face	EN 558-1/DIN 3202 F1
End Flange	EN 1092-1/DIN 2501
Butt Weld	EN 12627
Class	PN16, PN25, PN40

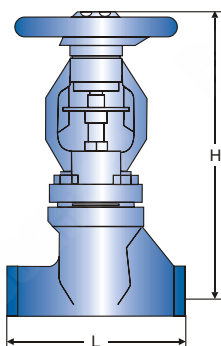

PN16 DIMENSIONS

SIZE (DN)	15	20	25	32	40	50
L	130	150	160	180	200	230
H(closed)	206	208	218	224	245	250
Stroke	8	8	10	10	15	16
W.T(kg)	2.6	2.8	3.5	4.2	5.8	7.0
KV	4.6	8	13.2	21.0	33.0	51.0

PN25 DIMENSIONS

SIZE (DN)	15	20	25	32	40	50
L	130	150	160	180	200	230
H(closed)	206	208	218	224	245	250
Stroke	8	8	10	10	15	16
W.T(kg)	2.6	2.8	3.5	4.2	5.8	7.0
KV	4.6	8	13.2	21.0	33.0	51.0

PN 40 DIMENSIONS

SIZE (DN)	15	20	25	32	40	50
L	130	150	160	180	200	230
H(closed)	206	208	218	224	245	250
Stroke	8	8	10	10	15	16
W.T(kg)	2.6	2.8	3.5	4.2	5.8	7.0
KV	4.6	8	13.2	21.0	33.0	51.0

API/BS BELLOW GLOBE/GATE VALVE

- Cast Steel Gate Valve, Full Port or Reduced Bore
- Outside Screw and York, Rising Stem
- Double Bellow Sealed, Stem Position Indication
- Designed to API 602

Face to Face	DBV Standard
End Flange	ANSI B16.5
Socket Weld	ASME B16.11
Butt Weld	ANSI B16.25
Class	ANSI CL800

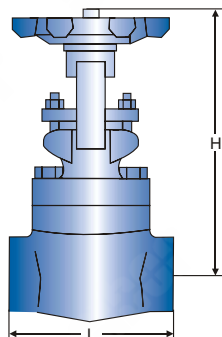

GATE DIMENSIONS

SIZE (DN)	15	20	25	32	40	50
L	79	92	111	120	120	140
H	205	275	287	330	365	421
Stroke	14	20	20	27	37	49
W.T(kg)	2.8	3.2	5.5	7.3	9.2	15.3

GLOBE DIMENSIONS

SIZE (DN)	15	20	25	32	40	50
L	79	92	111	120	152	172
H	150	150	180	198	220	421
Stroke	8	8	11	12	14	15
W.T(kg)	1.7	1.9	3.3	5.2	6.8	10.6

SCREEN OPENINGS

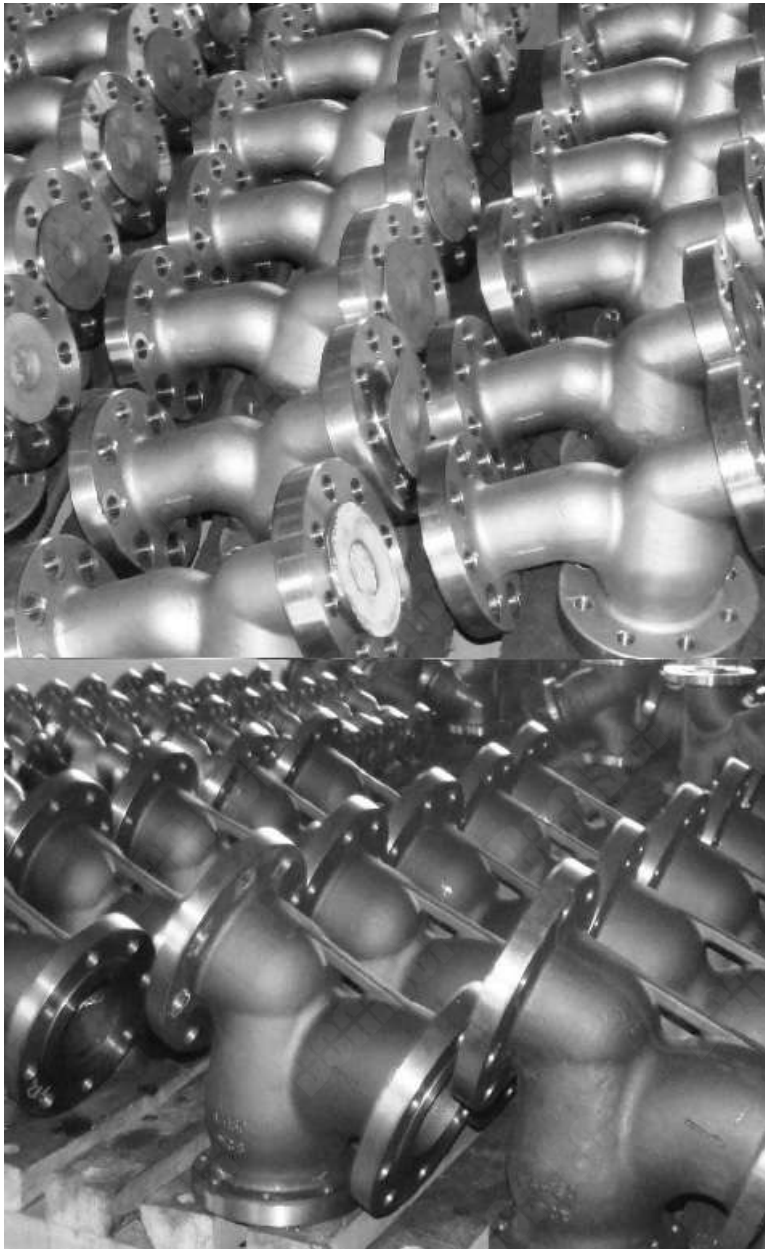

	100Mesh-30% O.A. 0.006" Openings
	80Mesh-36% O.A. 0.008" Openings
	60Mesh-38% O.A. 0.010" Openings
	40Mesh-41% O.A. 0.016" Openings
	30Mesh-45% O.A. 0.033" Openings
	20Mesh-49% O.A. 0.035" Openings
	0.027" Dia.-23% O.A.
	0.033" Dia.-28% O.A.
	3/64" Dia.-36% O.A.
	1/16" Dia.-37% O.A.
	3/32" Dia.-39% O.A.
	1/8" Dia.-40% O.A.
	5/32" Dia.-58% O.A.
	3/16" Dia.-50% O.A.
	1/4" Dia.-40% O.A.

Y Strainer

APPLICATIONS

- Process Industry
- Power Industry
- Oil and Gas

APPLICATIONS

- Chemical Industry
- Metal and Mining
- Water and Sewage
- Pulp and Paper

TYPES

- Y Type
- T Type
- Basket Type
- Duplex Type

FEATURES

- Low Pressure Drop
- Stream Lined Design
- Compact Structure
- Cast or Forged Fabrications

MATERIALS OF CONSTRUCTION ● CAST CARBON AND STAINLESS STEEL Y STRAINER

PART	CARBON STEEL	STAINLESS STEEL
Body	A216-WCB	A351-CF8M
Cover	A216-WCB	A351-CFM
Screen	304 Stainless Steel	304 Stainless Steel
Plug	A105	A182-316
Gasket	Teflon/Spiral Wound 304/GR	Teflon/Spiral Wound 304/GR
Stud	A193-B7	A193-B8-1
Nut	A194-2H	A194-8

MATERIALS OF CONSTRUCTION ● FORGED CARBON AND STAINLESS STEEL Y STRAINER

PART	CARBON STEEL	STAINLESS STEEL
Body	ASTMA105	A182 SS316
Cover	ASTMA105	A182 SS316
Screen	304 SS	A182 316 SS
Plug	A105	A182-316
Gasket	304 SS Spiral Wound	316 SS Spiral Wound

MATERIALS

- Carbon Steel
- Low Temperature Steel
- Chrome Alloy
- Stainless Steel
- Duplex Stainless Steel
- Gun Metal or Bronze
- Other Special Materials Available Upon Request

SIZES

- Casting: 2" Through 36"
- Forging: 1/2" Through 2"
- Fabricated: Customer's Size Upon Request
- Larger Size Available Upon Request

PRESURE

TEMPERATURE RATING

- Pressures to 3705PSIG
- Temperature to 800F

RATINGS

- ASME Class 150
- ASME Class 300
- ASME Class 600
- ASME Class 900
- ASME Class 1500
- ASME Class 800

Y TYPE STRAINER

- Cast Steel Strainer, Y Pattern
- Bolted Cover With Drain Plug
- Perforated Stainless Steel Screen
- Renewable Strainer Density
- Flanged or Butt-weld Ends
- Designed to ASME B16.34

Face to Face	ASME/ANSI B16.10
End Flange	ASME/ANSI B16.5
Butt Weld	ASME/ANSI B16.25
Class	ASME/ANSI CL150/300

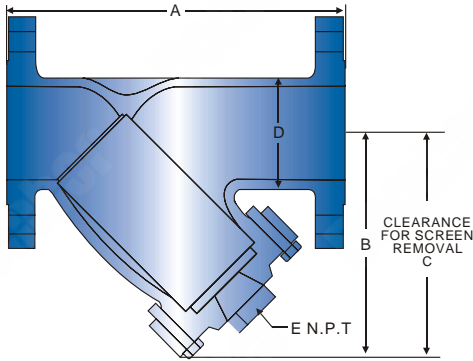

CLASS 150 DIMENSION

SIZE (in.)	A	B	C	D	E	W.T.(lbs)	Unit: inch
1/2"	6	3-7/8	4-3/4	1/2	1/4	5.5	
3/4"	7	4-1/4	5-3/4	3/4	3/8	8	
1"	7-1/2	4-3/4	6-3/8	1	1/2	10	
1-1/4"	8-3/4	5-9/16	8	1-1/4	1/2	16	
1-1/2"	9	5-5/8	9	1-1/2	1/2	18	
2"	8-5/8	5-7/8	7-1/2	2	1/2	20	
2-1/2"	10-1/4	7-1/2	10-1/2	2-1/2	3/4	27	
3"	11-5/8	7-11/16	10-7/8	3	1	41	
4"	14-3/8	9-1/8	13	4	1-1/2	63	
5"	17-5/8	11	17	5	2	99	
6"	18-5/8	13	18-3/8	6	2	133	
8"	24-3/8	15-5/16	21-5/8	8	2	222	
10"	26-1/16	19-1/8	27	10	2	409	
12"	30-3/8	22	31	12	2	605	

CLASS 300 DIMENSION

SIZE (in.)	A	B	C	D	E	W.T.(lbs)	Unit: inch
1/2"	6-1/2	4-1/4	5-3/4	1/2	1/4	8	
3/4"	7-3/4	5	6-3/4	3/4	3/8	14	
1"	7-7/8	5-1/2	8-1/8	1	1/2	15	
1-1/2"	10-1/2	7	10-1/4	1-1/2	1/2	32	
2"	9	5-11/16	8	2	1/2	25	
2-1/2"	10-7/8	7-3/16	10-1/4	2-1/2	1	38	
3"	12-5/8	8-1/2	11-1/2	3	1	56	
4"	14-5/8	9-5/8	13-5/8	4	1-1/2	90	
5"	18-1/2	15-3/8	21-1/2	5	2	180	
6"	19-3/4	15	21-1/2	6	2	203	
8"	25	16-1/2	22	8	2	323	
10"	27-5/8	21-3/16	30	10	2	571	
12"	32-7/8	24-5/16	34-3/8	12	2	893	

PRESSURE/TEMPERATURE CHART CLASS 150
ASME B16.34

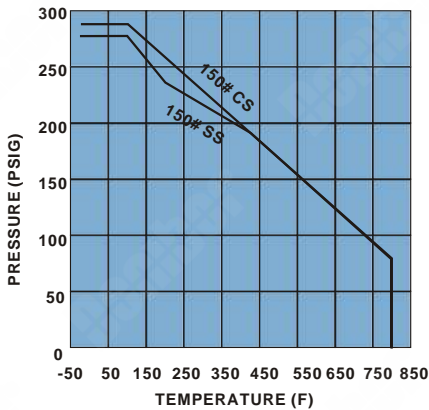

PRESSURE DROP VS FLOW RATE CLASS 150

SIZES 2" - 12"

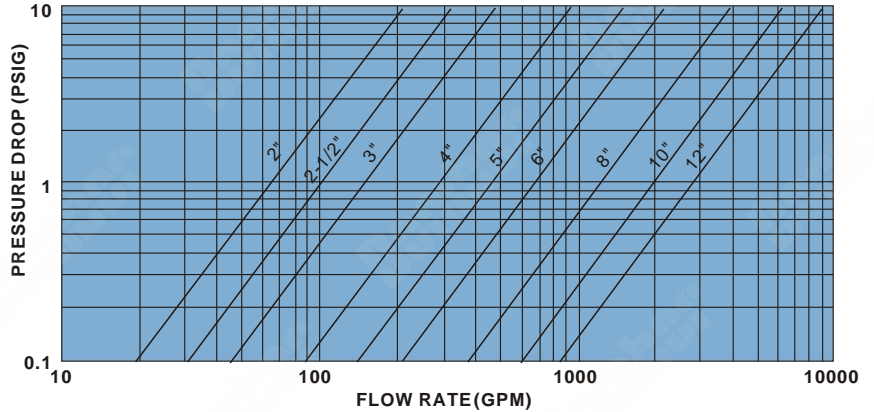

PRESSURE/TEMPERATURE CHART CLASS 300
ASME B16.34

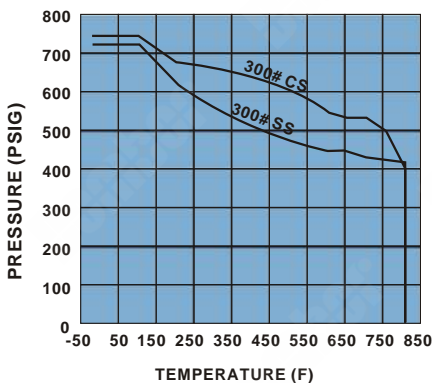

PRESSURE DROP VS FLOW RATE CLASS 300

SIZES 2" - 12"

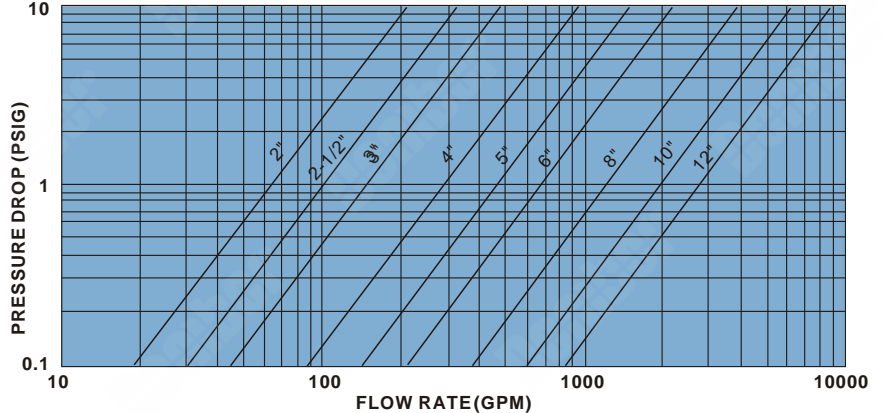

Y TYPE STRAINER

- Cast Steel Strainer, Y Pattern
- Bolted Cover With Drain Plug
- Perforated Stainless Steel Screen
- Renewable Strainer Density
- Flanged or Butt-weld Ends
- Designed to ASME B16.34

Face to Face	ASME/ANSI B16.10
End Flange	ASME/ANSI B16.5
Butt Weld	ASME/ANSI B16.25
Class	ASME/ANSI CL600/900

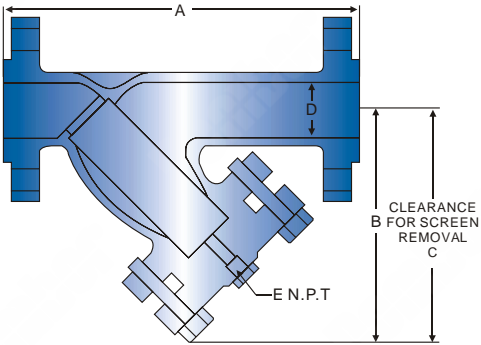

* Class 900 Y strainers are not furnished with a drain/blow-down connection, Consult factory if required.

CLASS 600 DIMENSION

SIZE (in.)	A	B	C	D	E	W.T.(lbs)
2"	12-1/2	8	9-1/4	2	1/2	46
3"	15-5/8	10-1/8	11-3/8	3	1-1/4	93
4"	20	13	14-1/4	4	1-1/2	187
6"	25-1/2	17	18-1/4	6	2	403
8"	30	21-3/8	22-11/16	8	2	660
10"	37-5/8	24-3/4	26	10	2	1428
12"	42	30	31-1/4	12	2	1608

Unit: inch

CLASS 900 DIMENSIONS

SIZE (in.)	A	B	C	D	W.T.(Lb)
2"	16-1/4	10-1/2	14-7/8	1.87	125
3"	20-1/4	12-3/4	18	2.87	163
4"	23-1/4	15	21-1/4	3.87	253
6"	27-3/4	18-7/8	26-5/8	5.75	580
8"	34-1/2	22-5/8	32	7.50	1080

Unit: inch

PRESSURE/TEMPERATURE CHART CLASS 600
ASME B16.34

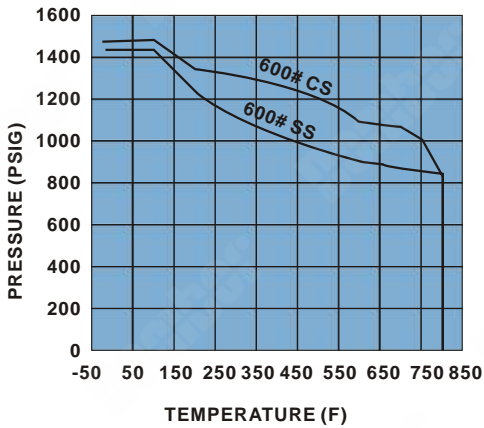

PRESSURE DROP VS FLOW RATE CLASS 600

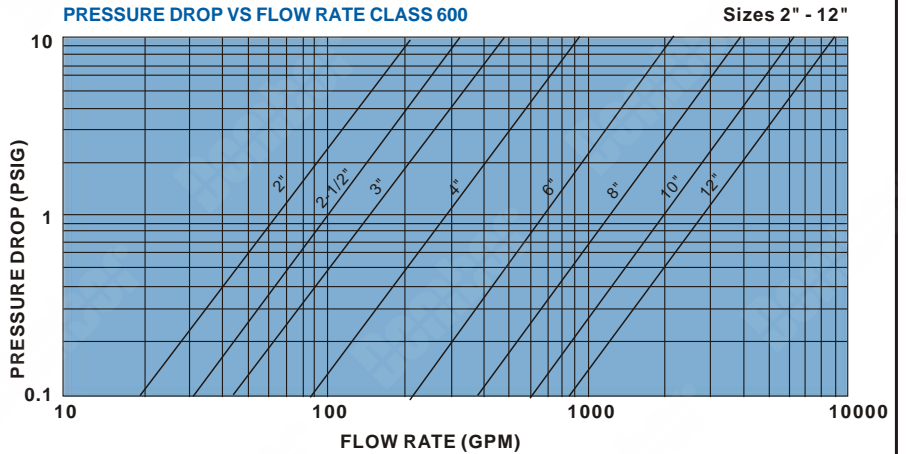

PRESSURE/TEMPERATURE CHART CLASS 900
ASME B16.34

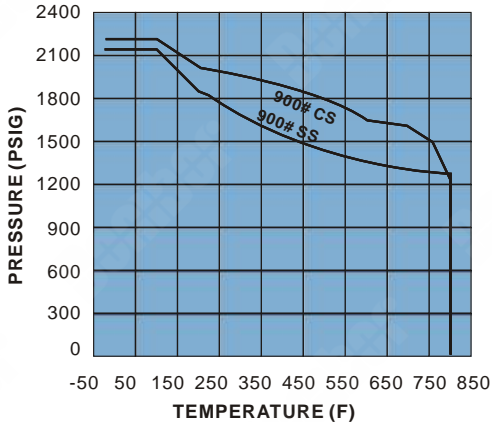

PRESSURE DROP VS FLOW RATE CLASS 900

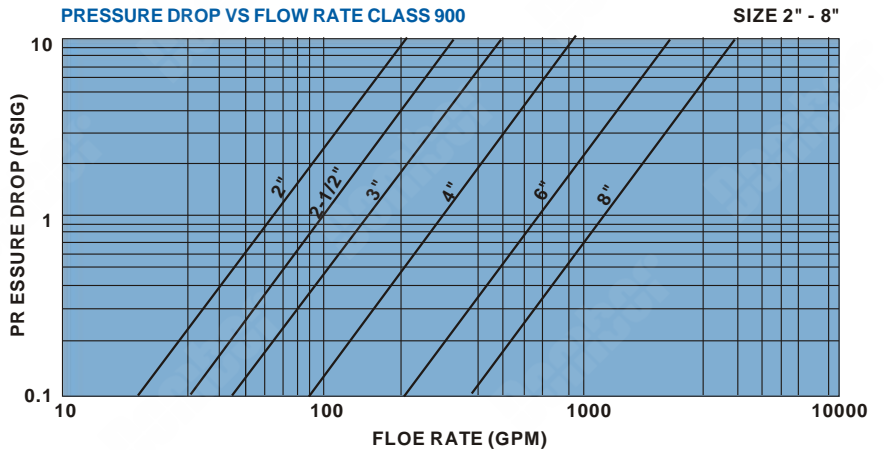

Y TYPE STRAINER

- Cast Steel Strainer, Y Pattern
- Bolted Cover With Drain Plug
- Perforated Stainless Steel Screen
- Renewable Strainer Density
- Flanged or Butt-weld Ends
- Designed to ASME B16.34

Face to Face	ASME/ANSI B16.10
End Flange	ASME/ANSI B16.5
Butt Weld	ASME/ANSI B16.25
Class	ASME/ANSI CL1500

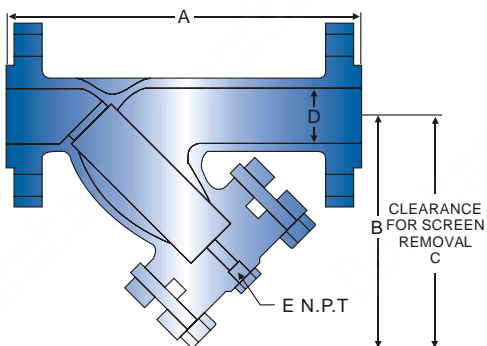

CLASS 1500 DIMENSION

SIZE(in.)	A	B	C	D	W.T(lbs)	Unit: inch
2"	16-1/4	10-1/2	14-7/8	1-7/8	125	
2-1/2"	19-3/8	13-3/8	14-1/2	2-1/4	142	
3"	22-1/4	14-1/2	20-1/2	2-3/4	243	
4"	25-1/4	16-3/8	23	3-5/8	388	
6"	32	21-3/4	30-1/2	5-3/8	817	

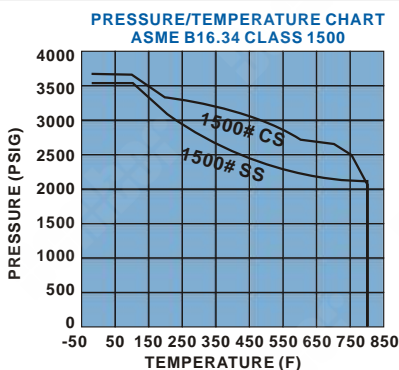
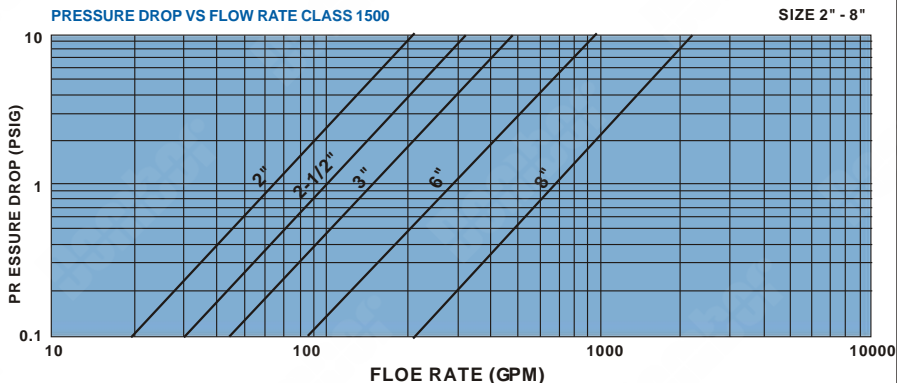

FORGED STEEL Y STRAINER

- Cast Steel Strainer, Y Pattern
- Bolted Cover With Drain Plug
- Perforated Stainless Steel Screen
- Renewable Strainer Density
- Threaded or Welded Ends
- Designed to ASME B16.34

Face to Face	ASME/ANSI B16.10
End Flange	ASME/ANSI B16.5
Butt Weld	ASME/ANSI B16.25
Class	ASME/ANSI CL800~CL1500

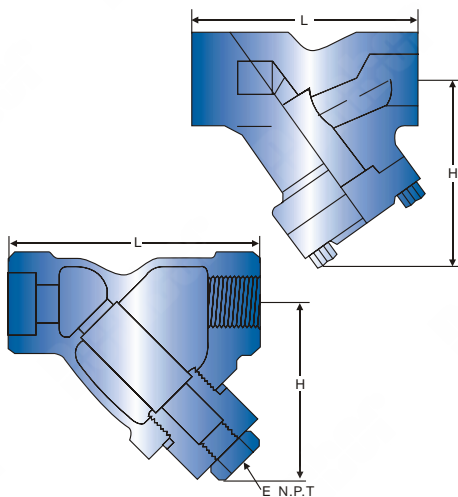

CL800 DIMENSIONS

(R.P) (F.P)	1/4	1/2	3/4	1	1-1/4	2	1-1/2	2-1/2	Unit: mm
L	98	98	98	111	140	140	155	170	
H	70	70	70	100	110	120	120	150	
α	7	9	13	17.5	30	30	35	46	
W.T(kg)	2.2	2.2	2.1	4.2	8.9	8.9	10	18.6	

CL900~1500 DIMENSIONS

(F.P)	3/8	1/2	3/4	1	1-1/4	1-1/2	2	Unit: mm
L	98	111	111	140	140	155	170	
H	70	70	100	110	120	120	150	
α	9	12	15	20	28	32	40	
W.T(kg)	2.1	4.2	9	8.9	10	18.6	20	

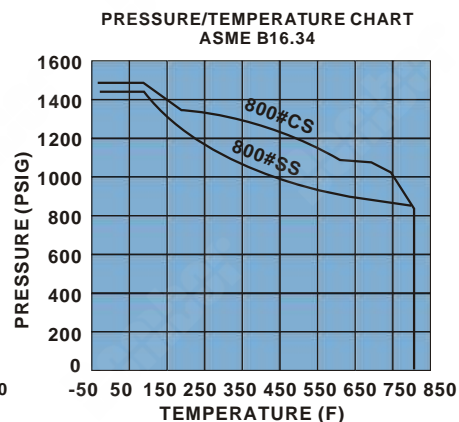
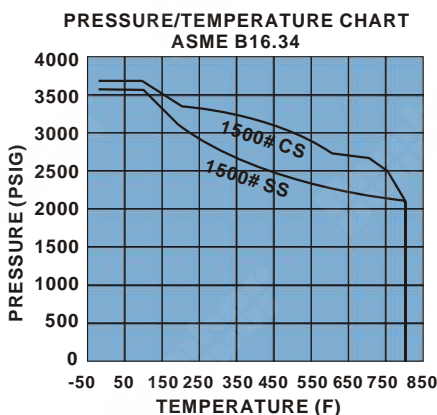

EN&DIN Y-STRAINER

- Cast Steel Strainer, Y Pattern
- Bolted Cover With Drain Plug
- Perforated Stainless Steel Screen
- Renewable Strainer Density
- Flanged or Butt-weld Ends
- Designed to EN13709

Face to Face	EN 558-1/DIN 3202 F1
End Flange	EN 1092/DIN 2543
Butt Weld	EN 12627
Class	PN16, PN25

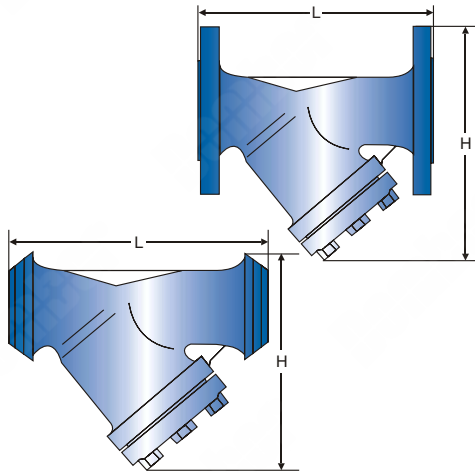

PN16 DIMENSIONS

SIZE (DN)	15	20	25	32	40	50	65	80	100	125	150	200	250	300	350	400
L	130.0	150.0	160.0	180.0	200.0	230.0	290.0	310.0	350.0	400.0	480.0	600.0	730.0	850.0	980.0	1100.0
H	85.0	95.0	110.0	125.0	145.0	155.0	170.0	205.0	230.0	270.0	318.0	400.0	555.0	620.0	700.0	820.0
WT FLG (kg)	2.8	3.8	5.3	7.2	9.0	11.8	16.2	22.4	35.0	45.4	62.0	132.0	220.0	330.0	540.0	830.0
B.W (kg)	1.9	2.8	3.8	4.8	6.2	8.3	11.8	17.8	28.6	37.0	51.2	120.0	203.0	308.0	510.0	788.0
KV	6.3	11.0	17.5	28.0	44.0	69.0	118.0	178.0	270.0	420.0	620.0	1100.0	1700.0	2500.0	3400.0	4400.0

PN25 DIMENSIONS

SIZE (DN)	15	20	25	32	40	50	65	80	100	125	150	200	250	300	350	400
L	130.0	150.0	160.0	180.0	200.0	230.0	290.0	310.0	350.0	400.0	480.0	600.0	730.0	850.0	980.0	1100.0
H	85.0	95.0	110.0	125.0	145.0	155.0	170.0	205.0	230.0	270.0	318.0	400.0	555.0	620.0	700.0	820.0
WT FLG (kg)	2.8	3.8	5.3	7.2	9.0	11.8	16.8	24.0	38.8	50.1	68.0	142.6	233.4	350.0	574.0	875.0
B.W (kg)	2.0	2.9	4.0	5.0	6.5	8.6	12.2	18.5	29.7	38.1	53.4	123.0	208.0	315.0	540.0	835.0
KV	6.3	11.0	17.5	28.0	44.0	69.0	118.0	178.0	270.0	420.0	620.0	1100.0	1700.0	2500.0	3400.0	4400.0

EN&DIN Y-STRAINER

- Cast Steel Strainer, Y Pattern
- Bolted Cover With Drain Plug
- Perforated Stainless Steel Screen
- Renewable Strainer Density
- Flanged or Butt-weld Ends
- Designed to EN13709

Face to Face	EN 558-1/DIN 3202 F1
End Flange	EN 1092/DIN 2543
Butt Weld	EN 12627
Class	PN40

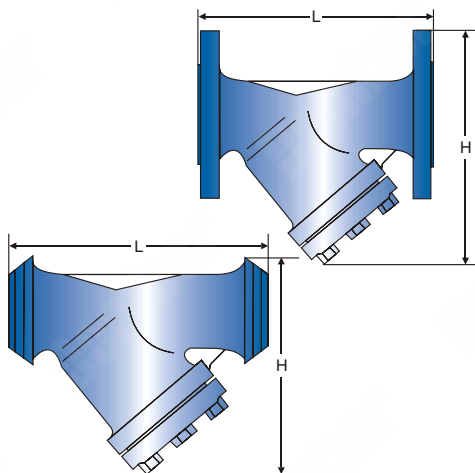

PN40 DIMENSIONS

SIZE (DN)	15	20	25	32	40	50	65	80	100	125	150	200	250	300	350	400
L	130.0	150.0	160.0	180.0	200.0	230.0	290.0	310.0	350.0	400.0	480.0	600.0	730.0	850.0	980.0	1100.0
H	85.0	95.0	110.0	125.0	145.0	155.0	170.0	205.0	230.0	270.0	318.0	400.0	555.0	620.0	700.0	820.0
WT FLG (kg)	2.8	3.8	5.3	7.2	9.0	11.8	17.4	24.6	39.7	52.5	70.4	153.0	250.0	360.0	614.0	940.0
B.W (kg)	2.1	3.0	4.3	5.4	7.0	9.1	13.0	19.8	31.4	40.3	58.8	129.0	223.0	348.0	587.0	887.0
KV	6.3	11.0	17.5	28.0	44.0	69.0	118.0	178.0	270.0	420.0	620.0	1100.0	1700.0	2500.0	3400.0	4400.0



BASKET STRAINER

- Cast Steel Strainer, Y Pattern
- Bolted Cover With Drain Plug
- Perforated Stainless Steel Screen
- Renewable Strainer Density
- Flanged or Butt-weld Ends
- Designed to ASME B16.34

Face to Face	ASME/ANSI B16.10
End Flange	ASME/ANSI B16.5
Butt Weld	ASME/ANSI B16.25
Class	ASME/ANSI CL150

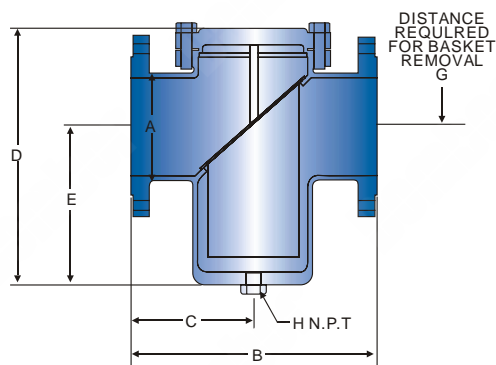

CLASS 150 DIMENSION

SIZE (in.)	A	B	C	D	E	F	G	H	W.T(lbs)
2"	2	8-1/8	4-1/16	9-9/16	5-5/8	3-1/4	12-1/2	1	29
2-1/2"	2-1/2	8-3/4	4-3/8	10-13/16	5-15/16	3-3/9	14	1	33
3"	3	9-7/8	4-15/16	12-1/2	7-9/16	3-9/16	15-3/8	1	48
4"	4	11-1/2	5-3/4	16	10-1/9	4-5/8	21-1/4	1	69
5"	5	13-1/8	6-9/16	15-7/8	9-1/2	7-1/2	22-1/4	1	105
6"	6	14-7/8	7-7/16	17-3/16	10-5/16	6-3/8	22-1/2	1	121
8"	8	18-3/4	9-3/8	21-15/16	13-1/16	8-7/8	29-3/8	1	214
10"	10	20-1/8	10-1/16	25	13-3/8	10-5/8	35	1	309
12"	12	26-1/4	13-1/8	30-11/16	17	14-7/8	42-1/2	1	476



BASKET U TYPE STRAINER

- Cast Steel Strainer, Y Pattern
- Bolted Cover With Drain Plug
- Perforated Stainless Steel Screen
- Renewable Strainer Density
- Flanged or Butt-weld Ends
- Designed to ASME B16.34

Face to Face	ASME/ANSI B16.10
End Flange	ASME/ANSI B16.5
Butt Weld	ASME/ANSI B16.25
Class	ASME/ANSI CL150

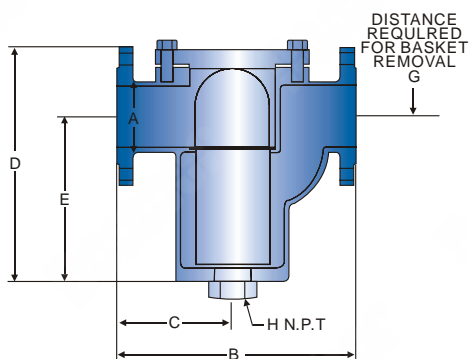

CLASS 150 DIMENSION

SIZE (in.)	A	B	C	D	E	F	G	H NPT	W.T(lbs)
1-1/2"	1-1/2	9-1/2	4-3/4	10-1/4	6-7/8	3-7/16	13-1/2	1/2	30
2"	2	10-1/2	5-1/4	11-13/16	8-3/16	4-1/8	15-5/8	3/4	46
3"	3	13-1/8	6-9/16	15-9/16	11-3/16	5-3/8	19-3/4	1	78
4"	4	17-1/4	8-7/8	16-1/8	11-7/16	6-11/16	20-3/4	2	114
6"	6	19-5/8	10-7/8	25-9/16	19-5/16	10	31-1/8	2	241
8"	8	27	14-5/8	35-7/16	27-15/16	12-5/16	42-1/4	2	432



For horizontal installation

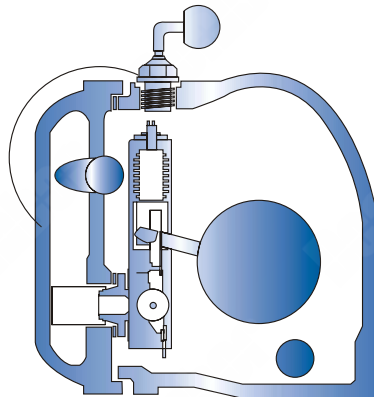

For vertical installation

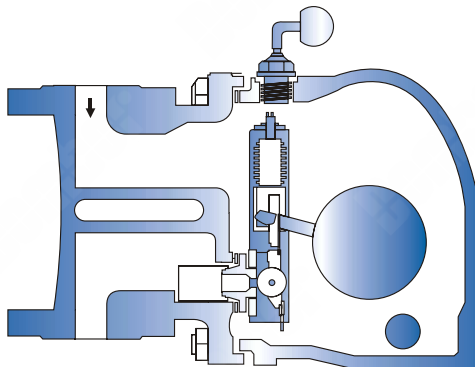

DESCRIPTION

DBV Ball float traps with rolling ball valve and Duplex control (thermostatic bellows for automatic air-venting) for draining large condensate flowrates from steam systems.

With Simplex control (without bellows) and hand-vent valve for the discharge of cold condensate or distillates and for draining superheated steam, gas or compressed-air lines.

For horizontal and vertical lines

Body with flanged cover. After removing the cover the control unit is easily accessible without removing the trap from the line.

On request:

Float lifting lever

Sightglass cover

Hand vent valve for traps with Duplex control

PRESSURE/TEMPERATURE RATING

	PN 16	PN 25	PN 40
Max. Service pressure [Barg]	16	13	38
Max. Service pressure [psig]	232	189	550
Max. Temperature [° C]	120	300	120
Max. Temperature [° F]	248	572	248
Max. Differential pressure (inlet pressure minus outlet pressure) [Barg]	13	32	
Max. Differential pressure (inlet pressure minus outlet pressure) [psig]	(8,4, or 2)	(22, 13, 8, 4, or 2)	
Max. temperature for design with sightglass cover*) [° C]	189	465	
Max. temperature for design with sightglass cover*) [° F]	(116, 58, 29)	(319, 189, 116, 58, 29)	
Max. temperature for design with sightglass cover*) [° C]	240		
Max. temperature for design with sightglass cover*) [° F]	464		

*) Please note: pH values above 9 and temperatures exceeding 200° C (392° F) may reduce the life of the sightglass.

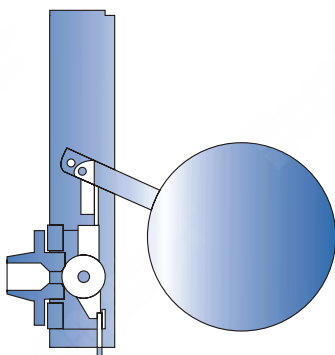

Control unit Simplex
(without thermostatic bellows)

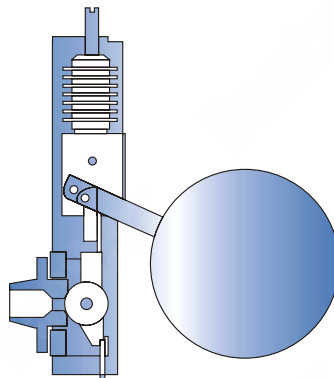

Control unit Duplex
(with thermostatic bellows
for automatic air-venting)

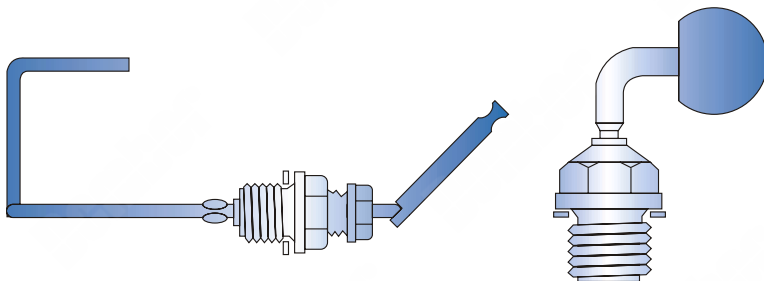

Float lifting lever
(on request)

Hand vent valve
(standard for Simplex design)

CONNECTIONS

- Flanged Ends to
 - ◆ EN 1092-2, form B
 - ◆ DIN 2545, form C
 - ◆ ASME B 16.5
- Socket-weld ends
- Butt-weld ends
- Threaded Ends to BSP or NPT

MATERIALS

- Carbon Steel
- Stainless Steel
- Duplex Steel
- Special Alloy
- Cast Iron
- Ductile Iron

PRESSURE RATINGS

- ANSI to CLASS 150, 300, 600
- DIN or EN to PN6, 10, 16, 25, 40, 64
- JIS to 10K

The products meet the requirement of the EC Pressure Equipment Directive (PED) No. 97/23. DN 40/50 with CE marking. DN 15-25 is excluded from the scope of the PED and not entitled to bear the marking.

FREE FLOATING BALL STEAM TRAP

- Cast or Forged Steel Steam Trap
- Free Floating Ball, Bolted Cover
- Horizontal or Vertical Lines
- Designed to EN/DIN Standard

Face to Face	EN 558/DIN 3202
End Flange	EN 1092/DIN 2501
Butt Weld	EN 12627
Class	PN16, PN25, PN40

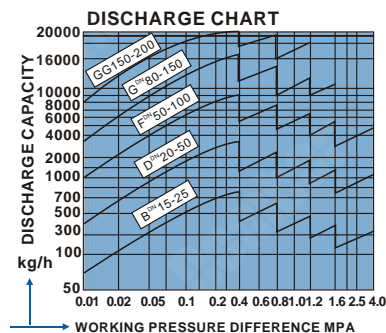
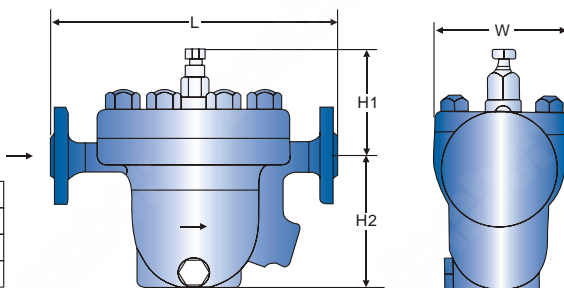

TECHNICAL PARAMETER

ITEM	SIZE (DN)	END CONNECTION	WORKING PRESSURE	MAX. ALLOWABLE TEMPERATURE(°C)	L	OVERALL DIMENSION				W.T (kg)
						H1	H2	W	Unit: mm	
CS11/61H-16 C-B	15~25	THREAD S.W	0.01~1.6	300	150/170	85/90	105/120	100/120	5/8.5	
CS11H-16C-D	32~50			300	270	100	165	175	14	
CS41H-16C-B	15~20/25	FLG	0.01~4.0	300	195/215	100	115	100	10	
CS41H-25-B	15~20/25			350	210/230	100	120	120	11	
CS41H-40-B	15~20/25			425	250	100	130	120	12.5	
CS41H-16C-D	20~32	FLG	0.01~4.0	300	270	105	165	175	16.5	
CS41H-25-D	40/50			350	280/290	105	165	175	18.5	
CS41H-40-D	20~50			425	350	125	190	200	27	
CS41H-16C-F	50~65/80	FLG	0.01~4.0	300	400/430	130	250	250	52	
CS41H-25-F	50~65/80~100			350	430/460	130	260	250	67	
CS41H-40-F	50~65/80~100			425	430/460	130	260	250	69	
CS41H-16C-G	80~100	FLG	0.01~4.0	300	550	150	310	285	85	
CS41H-25-G	80~150			350	570	190	340	315	108	
CS41H-40-G	80~150			425	570	190	340	315	116	
CS41H-16C-GG	150~200	FLG	0.01~1.6	350	575	210	360	330	143	

LEVER FREE FLOATING BALL STEAM TRAP

- Cast or Forged Steel Steam Trap
- Lever Pattern, Free Floating Ball
- Bolted Cover, Horizontal or Vertical Lines
- Designed to EN/DIN Standard

Face to Face	EN 558
End Flange	EN 1092
Butt Weld	EN 12627
Class	PN16, PN25

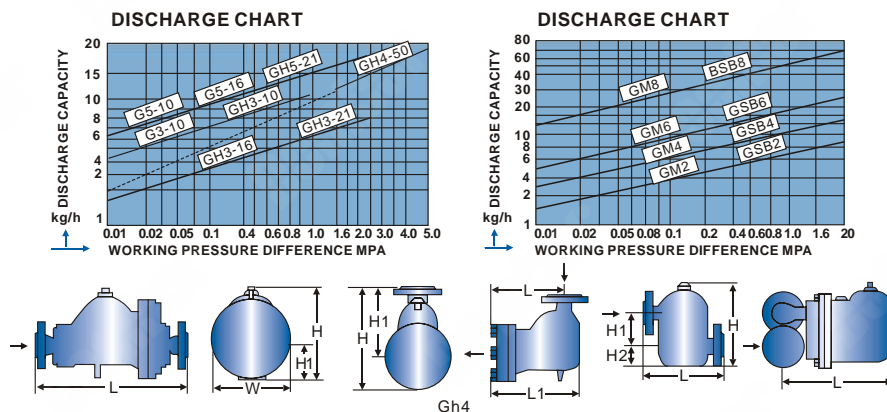

TECHNICAL PARAMETER

ITEM	SIZE (DN)	END CONNECTION	WORKING PRESSURE	MAX. ALLOWABLE TEMPERATURE(°C)	L	OVERALL DIMENSION					W.T (kg)
						L1	H	H1	H2	W	
G3-10-16R	25~50	FLG	0.01~1.6	300	435	-	260	-	85	215	28
G5-16R	50~100	FLG	0.01~1.6	300	570	-	260	-	85	215	35
GH3-10R	25~32	FLG	0.01~2.1	425	425	-	260	-	85	215	28
GH3-16R	40			425	435	-	260	-	88	215	30
GH3-21R	50			425	455	-	260	-	88	215	32
GH 4-50	40~80	FLG	0.01~5.0	425	345	428	430	-	340	270	75
GH 5-16R	50~100	FLG	0.01~2.1	425	360	317	-	117	270	35	
GH 5-21R					570						
GM 2	25~50	FLG	0.01~1.0 0.01~2.0	425	200	310	235	80	95	-	21
GM 4	32~50	FLG	0.01~1.0 0.01~2.0	425	200	380	320	85	105	-	40
GM 6	40~80	FLG	0.01~1.0 0.01~2.0	425	270	440	345	90	125	-	52
GM 8	80~100	FLG	0.01~1.0 0.01~2.0	425	350	550	460	118	170	-	125

FLOATING BALL STEAM TRAP

- Cast or Forged Steel Steam Trap, Floating Ball
- Bolted Cover, Horizontal or Vertical Lines
- Designed to EN/DIN Standard

Face to Face	EN 558
End Flange	EN 1092
Butt Weld	EN 12627
Class	PN16, PN25, PN40

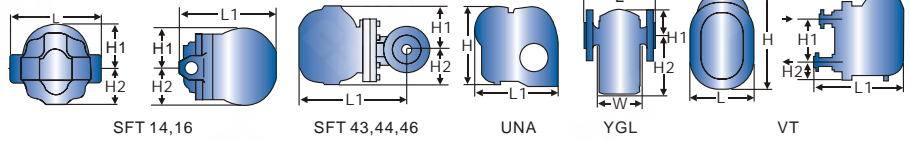
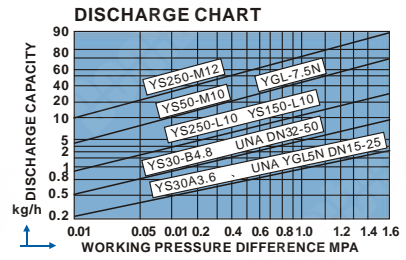
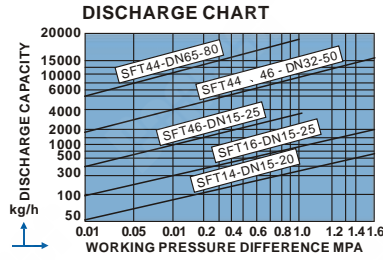

TECHNICAL PARAMETER

ITEM	SIZE (DN)	END CONNECTION	WORKING PRESSURE	MAX. ALLOWABLE TEMPERATURE(°C)	OVERALL DIMENSION				
					L	L1	H1	H2	W
SFT14-16	15~20	THREAD	0.01~1.6	250	125	155	65	55	155
SFT16-16	15~25	FLG	0.01~1.6	250	190	220	120	80	140
SFT44-16	15~20/25	FLG	0.01~1.6	350	150/160	255	85	115	110
(SFT43)	32~50				230	355	175	110	190
(SFT46)	65~80	FLG	0.01~1.6	350	270	420	218	125	220
UNA23H	15~20/25				150/160	145	60	128	90
UNA26H	32~50	FLG	0.01~4.0	350	230	235	135	155	150
UNA23L	15~20/25	FLANGE	0.01~4.0	350	150/160	145	60	128	90
UNA26L	32~50	(VERTICAL)			230	235	135	155	150
YGL5N	25~50	FLG	0.01~2.0	350	270	240	130	160	-
YGL7.5N	65~100				450	390	150	260	-
VT50-K10	65~100	FLG	0.01~1.6	350	275	445	190	115	-
VT250-M12					275	520	230	115	-
VT150-L10	50~65	FLG	0.01~1.6	350	225	440	190	110	-
VT250-L10									
VT30-A3.6	15~25	THREADED	0.01~1.6	350	130	162	65	107	-
VT30-B4.8	25~50	FLANGE			200	235	130	145	-

THERMOSTATIC FREE FLOATING BALL STEAM TRAP

- Cast or Forged Steel Steam Trap
- Thermostatic, Free Floating Ball
- Bolted Cover, Horizontal or Vertical Lines
- Designed to EN/DIN Standard

Face to Face	EN 558/DIN 3202
End Flange	EN 1092/DIN 2501
Butt Weld	EN 12627
Class	PN16, PN25, PN40

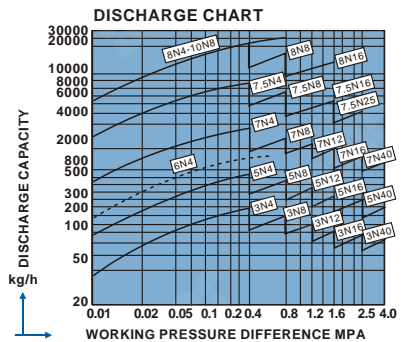
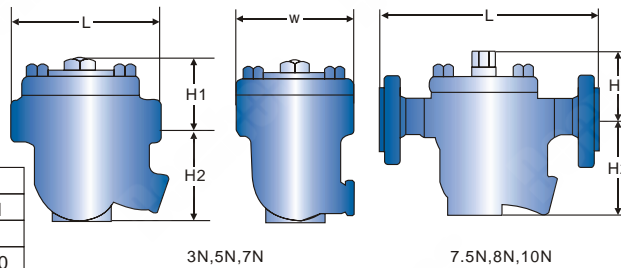

TECHNICAL PARAMETER

ITEM	SIZE (DN)	END CONNECTION	WORKING PRESSURE	MAX. ALLOWABLE TEMPERATURE(°C)	OVERALL DIMENSION				W.T (kg)
					L	H1	H2	W	
CS11/16H-16/40C-3N	15~20	THREAD S.W	0.01~4.0	350	120	85	95	82	3.5
CS11/16H-16/40C-5N	15~20/25	THREAD S.W	0.01~4.0	350	150	90	105	100	6.5
					170	90	125	120	8.5
CS11H-16/40C-7N	25~50	THREAD	0.01~4.0	350	270	105	165	175	15
CS41H-16/40C-3N	15~25	FLG	0.01~4.0	425	210	85	95	82	5.5
CS41H-16/40C-5N	15~50	FLG	0.01~4.0	425	230	95	125	120	14
CS41H-16/40C-6N	20~40	FLG	0.01~4.0	425	275	105	125	175	17
CS41H-16/40C-7N	25~50	FLG	0.01~4.0	425	320	120	190	200	26.5
CS41H-16C-7.5N	50~10	FLG	0.01~4.0	425	460	140	250	255	67
CS41H-16C-8N	65~150	FLG	0.01~1.6	350	560	185	340	320	115
CS41H-16C-10N	150~200	FLG	0.01~1.6	350	570	210	365	330	138

THERMOSTATIC BELLOW STEAM TRAP

- Cast or Forged Steel Steam Trap
- Thermostatic, Bolted Cover
- Horizontal or Vertical Lines
- Designed to EN/DIN Standard

Face to Face	EN 558
End Flange	EN 1092
Butt Weld	EN 12627
Class	PN16, PN25

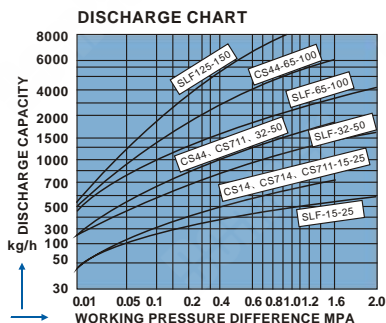
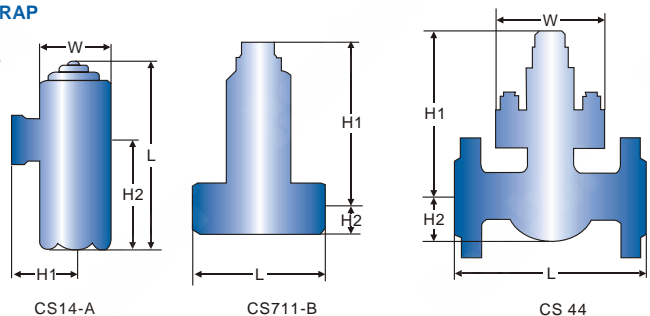

TECHNICAL PARAMETER

ITEM	SIZE (DN)	END CONNECTION	WORKING PRESSURE	MAX. ALLOWABLE TEMPERATURE(°C)	L	OVERALL DIMENSION			W.T (kg)
						H1	H2	W	
CS14F-16C	15~25	THREAD	0.01~1.6	220	145	40	85	40	1.6
	32~50				175	40	100	74	2.3
CS44F-16C	15~20/25	FLG	0.01~1.6	220	150/160	150	53	55	4.5
	32~50				230	160	75	120	13
	65~80/100				260/310	180	100	150	25
	125~150				350	210	130	170	35
CS714H-16A	15~25	THREAD	0.01~1.6	220	150	40	75	45	1.6
	32~50				190	65	100	75	3.3
CS711H-16B	15~25	THREAD	0.01~1.6	220	95	110	35	53	2.2
	32~50				120				4
SLF-20	15~20/25	FLG	0.01~2.0	250	150/160	180	70	40	5
	32~50				230		75	12.5	
SLF-10	65~80	FLG	0.01~2.0	250	250	205	100	170	23
SLF-20	100				310			25	
	125~150				350				34

THERMODYNAMIC STEAM TRAP

- Cast or Forged Steel Steam Trap
- Thermodynamic, Bolted Cover
- Horizontal or Vertical Lines
- Designed to EN/DIN Standard

Face to Face	EN 558
End Flange	EN 1092
Butt Weld	EN 12627
Class	PN16, PN25, PN40, PN64

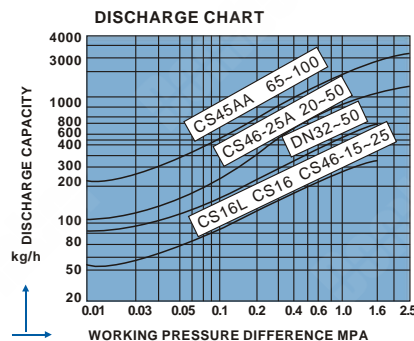
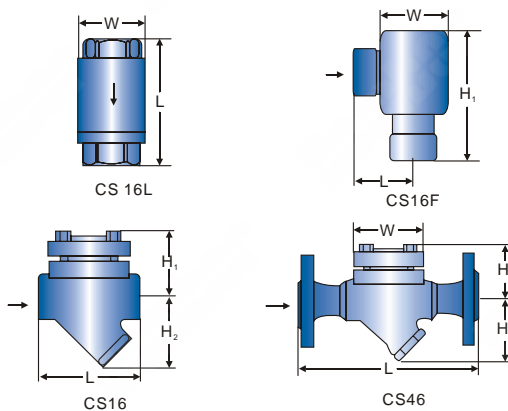

TECHNICAL PARAMETER

ITEM	SIZE (DN)	END CONNECTION	WORKING PRESSURE	MAX. ALLOWABLE TEMPERATURE(°C)	L	OVERALL DIMENSION			W.T (kg)
						H1	H2	W	
CS16H-16C	15~20	THREAD	0.01~1.6	250	100	58	55	70	2.5
	25				120				
	32~40				150	68	68	90	5
	50				160				
CS46H-16C	15~20	FLG	0.01~1.6	250	150	58	55	70	4.9
	25				160	85	60		
CS46H-16C	32~50	FLG	0.01~1.6	250	230	120	95	120	13
CS46H-16A	65~100	FLG	0.01~1.6	250	310	85	60	150	24
CS46H-25A	20~50	FLG	0.01~2.5	250	230			120	14
CS16H-16L	15~25	THREAD(Ver.)	0.01~1.6	250	100	103		80	2.3
CS16H-16F	15~25	THREAD(Ang.)	0.01~1.6	250	53				1.5

THERMODYNAMIC STEAM TRAP

- Forged Steel Steam Trap
- Thermodynamic, Bolted Cover
- Horizontal or Vertical Lines
- Designed to EN/DIN Standard

Face to Face	EN 558
End Flange	EN 1092
Butt Weld	EN 12627
Class	PN16, PN25, PN40, PN64

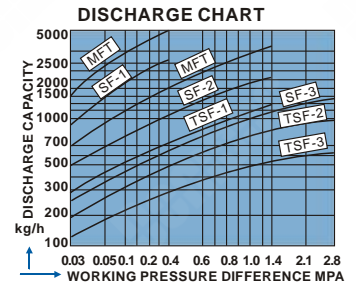
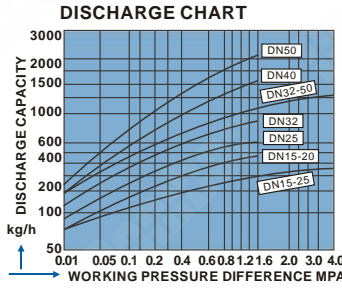
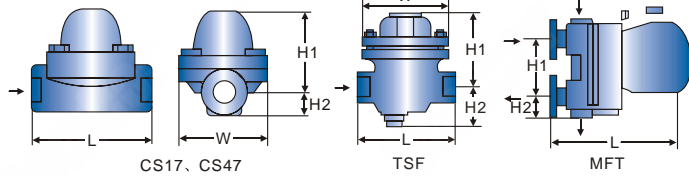

TECHNICAL PARAMETER

ITEM	SIZE (DN)	END CONNECTION	WORKING PRESSURE	MAX. ALLOWABLE TEMPERATURE(°C)	OVERALL DIMENSION					W.T (kg) Unit: mm
					L	L1	H1	H2	W	
CS17H-16/25C	15~20/25	THREAD	0.01~2.5	300	15~20/25	100/120	80	25	80	2/3
	32~50				190	120	45	90	4.7	
CS67H-16/25	15~20/25	S.W	0.01~2.5	300	15~20/25	100/120	80	25	80	2/3
	32~50				190	120	45	90	4/4.5	
CS47H-16C	15~20/25	FLG	0.01~1.6	250	15~20/25	150/160	80/85	25/25	80	4.7
	32~50				230	120	45	90	4/4.5	
CS47H-40	15~20/25	FLG	0.01~4.0	350	15~20/25	150/160	80	25	80	9
	32~50				230	120	45	90	4/4.5	
TSF1/2/3	15~20	THREAD	0.01~2.2	250	15~20	120/155	100/125	25/60	90/135	9.8
TSF1/2/3-16GF	15~20/25	FLG	0.01~2.8	350	15~20/25	210/230	100	25	90	3.5
	15~20				120/155	100/125	25/60	90/135	6	
SF1/2/3	15~20/25	THREAD	0.01~1.6	250	15~20/25	210/230	100	25	90	6.5
SF1/2/3-16GF	32~50	FLG	0.01~2.8	350	32~50	230	125	60	135	7.5
MFT-1/4	15~25	THREAD FLG	0.01~1.4	250	15~25	265	105	30	105	6.5/7.5
MFT-1/4	32~50	THREAD FLG	0.01~1.4	250	32~50	310	170	55	145	12.5

THERMODYNAMIC/THERMODYSTATIC STEAM TRAP

- Forged Steel Steam Trap, Bolted Cover
- Thermodynamic/Thermostatic
- Horizontal or Vertical Lines
- Designed to EN/DIN Standard

Face to Face	EN 558
End Flange	EN 1092
Butt Weld	EN 12627
Class	PN16, PN25, PN40, PN64

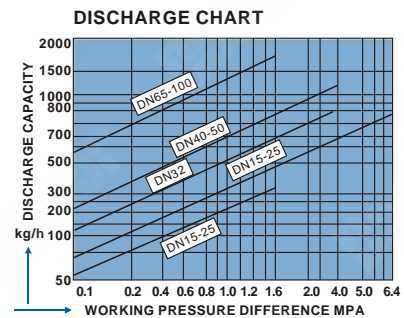
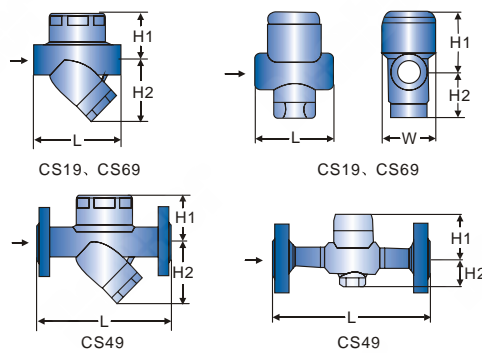

TECHNICAL PARAMETER

ITEM	SIZE (DN)	END CONNECTION	WORKING PRESSURE	MAX. ALLOWABLE TEMPERATURE(°C)	L	OVERALL DIMENSION			W.T (kg) Unit: mm
						H1	H2	W	
CS19/69H-16/25/40C	15~20	THREAD	0.01~4.0	350	85	65	55	53	1.7
	25	S.W			95				
	32				100	50	60		
	40	FLG			110	55	70	70	4.2
CS49H-16/25/40C	50				120	65	83		
	15~20	FLG	0.01~4.0	350	150	65	55	53	4.8
	25	FLG	0.01~4.0	350	160	83	65	65	9.5
CS49H-16C	32~50				230				
	65	FLG	0.01~1.6	350	270	87	73	75	24.5
	80				290				
100				310					
CS19/69H-64	15~25	THREAD S.W	0.01~6.4	425	120	35	100	108	6.5
CS49H-64	15~20	FLG	0.01~6.4	425	210	100	35	108	12.5
	25				230				

THERMODYNAMIC STEAM TRAP

- Forged Steel Steam Trap
- Thermodynamic, Bolted Cover
- Horizontal or Vertical Lines
- Designed to EN/DIN Standard

Face to Face	EN 558
End Flange	EN 1092
Butt Weld	EN 12627
Class	PN16, PN25, PN40, PN64

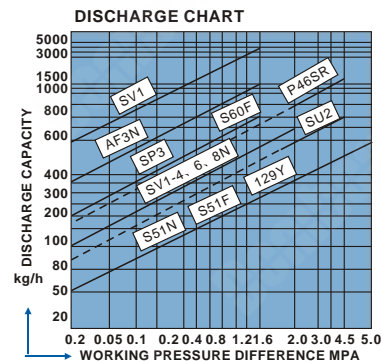
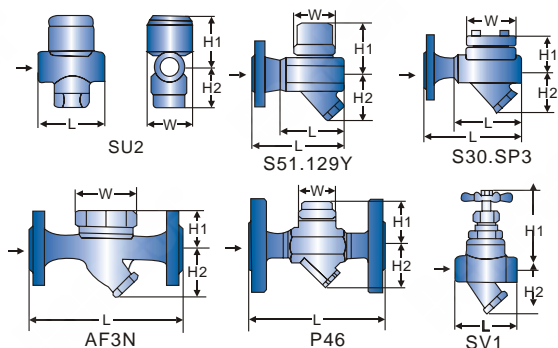

TECHNICAL PARAMETER

ITEM	SIZE (DN)	END CONNECTION	WORKING PRESSURE	MAX. ALLOWABLE TEMPERATURE(°C)	L	OVERALL DIMENSION			W.T (KG)
						H1	H2	W	
S51M/W	15~20/25	THREAD S.W	0.01~4.5	425	90/95	62	50	53	1.5
S51NF	15/20/25	FLG	0.01~5.0	425	140/165/175	62	50	53	
129 Y	15~25	THREAD	0.01~5.0	425	100	65	53	55	1.6
SU 2	15~25	THREAD	0.01~4.5	425	70	43	31	35	1.3
SU2F	15~20/25	FLG	0.01~4.5	425	150/160	43	31	35	
S30	15~20/25	THREAD	0.01~1.6	350	90/100	57	60	70	2.5
S30F	15~20/25	FLG	0.01~1.6	350	150/160	57	60	70	4.6
SP 3	15~20/25	THREAD	0.01~1.6	350	90/100	57	60	70	2.6
SP 3F	15~20/25	FLG	0.01~1.6	350	150/160	60	65	70	4.7
	32~50				230				10.5
AF3N	15~20/25	FLG	0.01~1.6	350	215/220	68	55	53	5.2
	32~50				265		105	100	13
P46SR	15~20/25	FLG	0.01~4.5	425	165/210	60	52	50	3.8/5.2
SV1-4, 6, 8N	15~20	THREAD	0.03~1.6	250	90	145	50	68	2.6
	15~25				110	160	65		
SV1-4, 6, 8NF	15~25	FLG	0.03~1.6	250	220/230	160/160	70/70	68	5.2

THERMODYNAMIC/THERMODYSTATIC STEAM TRAP

- Forged Steel Steam Trap, Bolted Cover
- Thermodynamic/Thermostatic
- Horizontal or Vertical Lines
- Designed to EN/DIN Standard

Face to Face	EN 558
End Flange	EN 1092
Butt Weld	EN 12627
Class	PN16, PN25, PN40, PN64

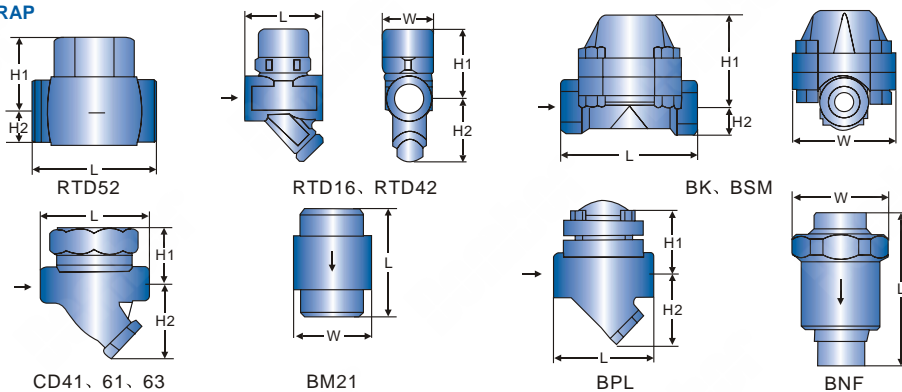

TECHNICAL PARAMETER

ITEM	SIZE (DN)	END CONNECTION	WORKING PRESSURE	MAX. ALLOWABLE TEMPERATURE(°C)	L	OVERALL DIMENSION			W
						H1	H2	W	
RTD52	15~20/25	THREAD	0.03~5.0	425	75/90	45/52	20/24	50/65	
RTD42	15~20/25	THREAD/FLG	0.03~4.0	400	90/95	60	48	50	
RTD16	15~20/25	THREAD	0.01~2.5	350	90/95	65	53	53	
CD 41, 61, 63	15~20/25	THREAD	0.03~5.0	400	75/90	45/55	20/25	48/65	
BPL21, 32-S	15~20/25	THREAD/FLG	0.01~2.5	250	90/100	58	60	70	
BM21, TTF	15~25	THREAD(Ver.)	0.01~2.1	250	85	-	-	65	
BNF4, 2	15~25	THREAD(Ver.)	0.01~2.1	250	120	-	-	60	
BK151/154/156	15~20/25	THREAD S.W	0.01~4.0	400	100/120	75	25	82	
BK274/276	15~25	Flange S.W	0.1~6.4	425	210/135	100	26	108	
BK284/286	15~25	Flange S.W	0.1~10.0	500	210/130	100	26	108	
BSM21, 24	15~20/25	THREAD	0.1~3.0	350	95/115	75	26	78	

BI-METAL STEAM TRAP WITH TEMP-REGULATION

- Forged Steel Steam Trap, Bolted Cover
- Dual Metal, Temperature Regulation
- Horizontal or Vertical Lines
- Designed to EN/DIN Standard

Face to Face	EN 558
End Flange	EN 1092
Butt Weld	EN 12627
Class	PN16, PN25

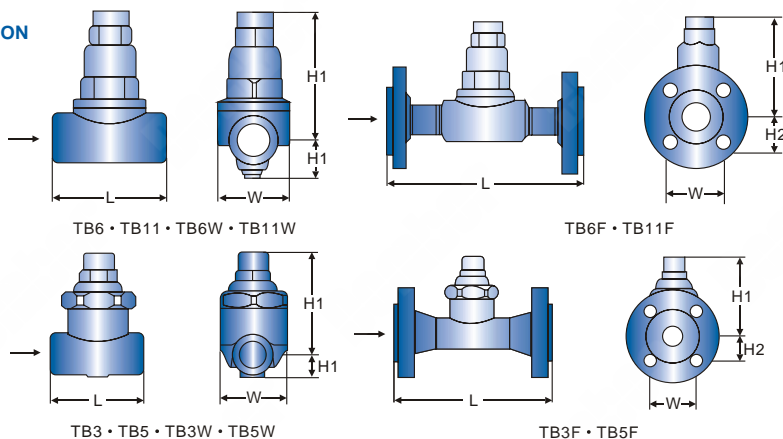

TECHNICAL PARAMETER

ITEM	SIZE (DN)	END CONNECTION	WORKING PRESSURE	MAX. ALLOWABLE TEMPERATURE(°C)	ADJUST THERMOSTAT(°C)	OVERALL DIMENSION				W.T(kg)
						L	H1	H2	W	
TB 6	15-20	THREAD	0.01~1.6	220	50~180	90	108	25	63	1.8
	25					95				
TB6F	15-20	FLG	0.01~1.6	220	50~180	150	108	25	63	3.2
	25					160				3.9
	32-50					230				5.6
TB6W	15-20	S.W	0.01~1.6	220	50~180	90	108	25	63	1.8
	25					95				
TB 11	15-20	THREAD	0.01~1.6	220	50~190	90	108	25	63	1.8
	25					95				
TB11F	15-20	FLG	0.01~1.6	220	50~190	150	108	25	63	3.2
	25					160				3.9
	32-50					230				5.6
TB11W	15-20	S.W	0.01~1.6	220	50~190	90	108	25	63	1.8
	25					95				
TB 3	15-20	THREAD	0.01~1.6	350	50~190	80	90	23	56	1.5
	25					85				
TB3F	15-20	FLG	0.01~1.6	350	50~190	150	90	23	56	3.3
	25					160				
TB3W	15-20	S.W	0.01~1.6	350	50~190	80	90	23	56	4.2
	25					85				
TB 5	15-20	THREAD	0.01~2.1	350	50~200	80	90	23	56	1.5
	25					85				
TB5F	15-20	FLG	0.01~2.1	350	50~200	150	90	23	56	3.3
	25					160				
TB5W	15-20	S.W	0.01~2.1	350	50~200	80	90	23	56	4.2
	25					85				

DISCHARGE CHART

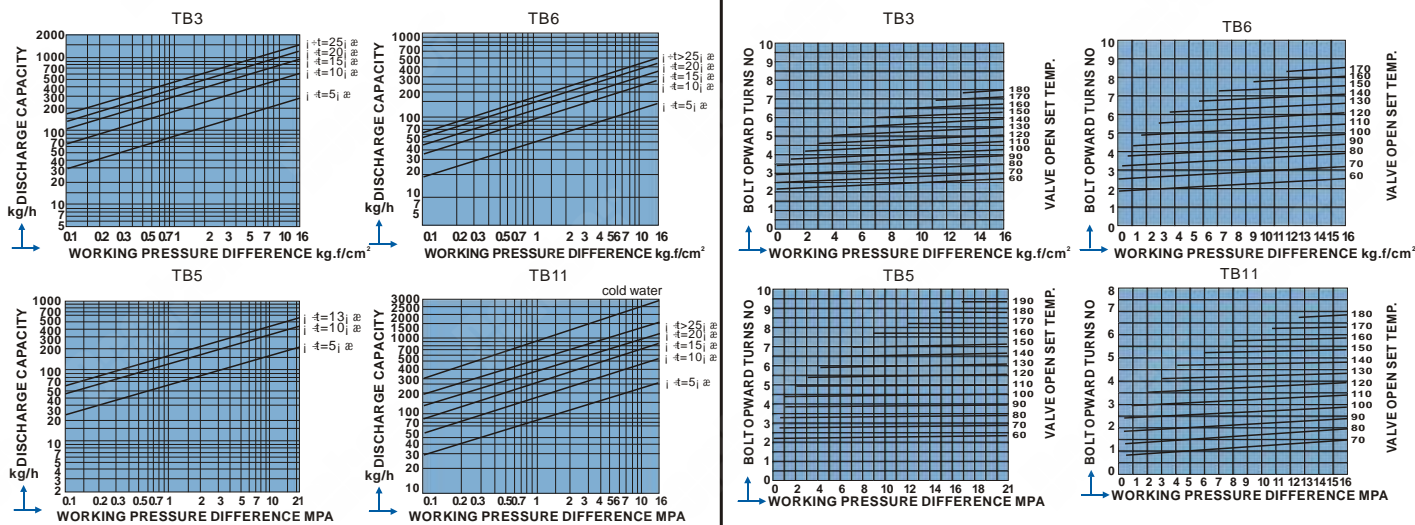

FREE SEMI-FLOATING BALL STEAM TRAP

- Forged Steel Steam Trap
- Dual Metal Constructure, Bolted Cover
- Horizontal or Vertical Lines
- Designed to EN/DIN Standard

Face to Face	EN 558
End Flange	EN 1092
Butt Weld	EN 12627
Class	PN16, PN25

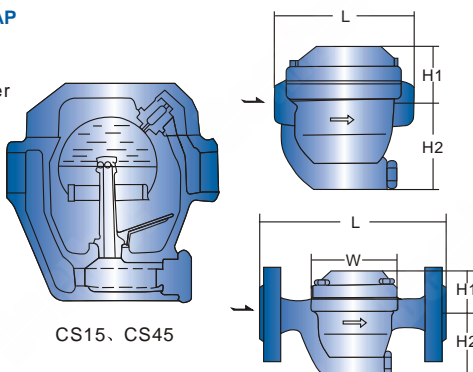

CS15, CS45

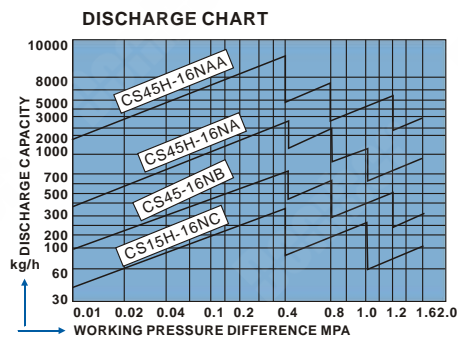

TECHNICAL PARAMETER

ITEM	SIZE (DN)	END CONNECTION	WORKING PRESSURE	MAX. ALLOWABLE TEMPERATURE(°C)	OVERALL DIMENSION				W.T (kg)
					L	H1	H2	W	
CS15H-16NC	15~25	THREAD	0.01~1.6	350	120/150	70	105	110/130	4/6.5
	32~50				250	90	120	170	15
CS45H-16NB	15~25	FLG	0.01~1.6	350	230	70	105	130	8.5
	32~50				270	90	120	170	18
CS45H-16NA	15~25	FLG	0.01~1.6	350	320	90	120	170	16
	32~50				320	95	130	180	21.5
CS45H-16NAA	65~100	FLG	0.01~1.6	350	350	125	170	230	49

HIGH PRESSURE AND HIGH TEMPERATURE FREE FLOATING BALL STEAM TRAP

- Forged Steel Steam Trap
- Free Floating Ball, Bolted Cover
- Horizontal or Vertical Lines
- High Pressure and High Temperature Application
- Designed to EN/DIN Standard

Face to Face	EN 558
End Flange	EN 1092
Butt Weld	EN 12627
Class	PN16~PN64

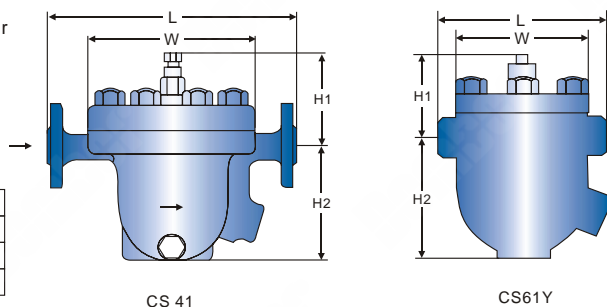

CS 41

CS61Y

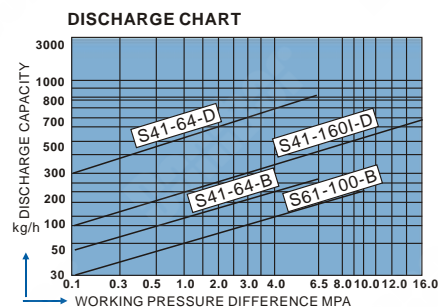

TECHNICAL PARAMETER

ITEM	SIZE (DN)	END CONNECTION	WORKING PRESSURE	MAX. ALLOWABLE TEMPERATURE(°C)	OVERALL DIMENSION				W.T (KG)
					L	H1	H2	W	
CS11/61H-16/40C-3N	15~25	S.W	0.1~6.4/10.0	425	190	90	135	145	13
CS11/61H-16/40C-5N	15~25	FLG	0.1~6.4	425	250	90	135	145	17
CS11H-16/40C-7N	15~50	FLG	0.1~6.4/10.0	425	350	125	190	220	45
CS41H-16/40C-3N	15~25	FLG	0.1~16.0	475	350	130	200	230	50
CS41H-16/40C-5N	32~40	FLG	0.1~16.0	475	350	130	200	230	54



DESIGN FEATURES

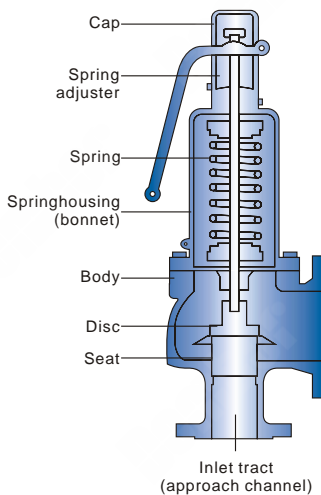
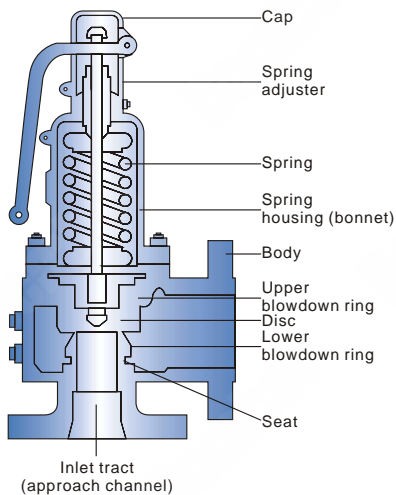

TYPICAL ASME VALVE

TYPICAL DIN VALVE

The valve inlet (or approach channel) design can be either a full-nozzle or a semi-nozzle type. Full-nozzle design has the entire 'wetted' inlet tract formed from one piece. The approach channels the only part of the safety valve that is exposed to the process fluid during normal operation, other than the disc, unless the valve is discharging.

Full-nozzles are usually incorporated in safety valves designed for process and high pressure applications, especially when the fluid is corrosive. Conversely, the semi-nozzle design consists of a seating ring fitted into the body, the top of which forms the seat of the valve. The advantage of this arrangement is that the seat can easily be replaced, without replacing the whole inlet. The disc is held against the nozzle seat (under normal operating conditions) by the spring, which is housed in an open or closed spring housing arrangement (or bonnet) mounted on top of the body. The discs used in rapid opening (pop type) safety valves are surrounded by a shroud, disc holder or huddling chamber which helps to produce the rapid opening characteristic.

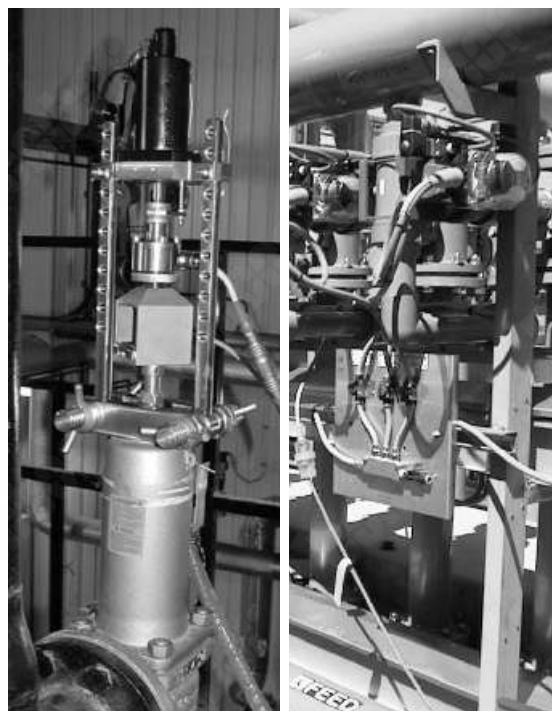

PRESSURE ADJUST

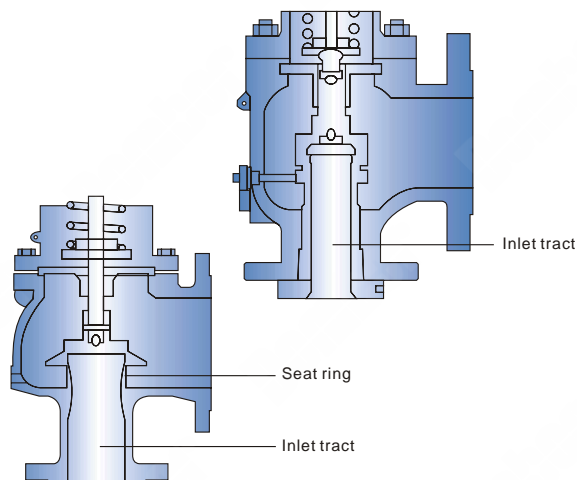

The closing force on the disc is provided by a spring, typically made from carbon steel.

The amount of compression on the spring is usually adjustable, using the spring adjuster, to alter the pressure at which the disc is lifted off its seat.

DISCHARGE CAPACITY

- 1. Flow area** - The minimum cross-sectional area between the inlet and the seat, at its narrowest point. The diameter of the flow area is represented by dimension 'd' in Figure a.
- 2. Curtain area** - The area of the cylindrical or conical discharge opening between the seating surfaces created by the lift of the disk above the seat. The diameter of the curtain area is represented by dimension 'd1' in Figure a.
- 3. Discharge area** - This is the lesser of the curtain and flow areas, which determines the flow through the valve.

$$\text{Flow area} = \pi d^2/4$$

Equation 9.1.1

$$\text{Curtain area} = \pi d_1 L$$

Equation 9.1.2

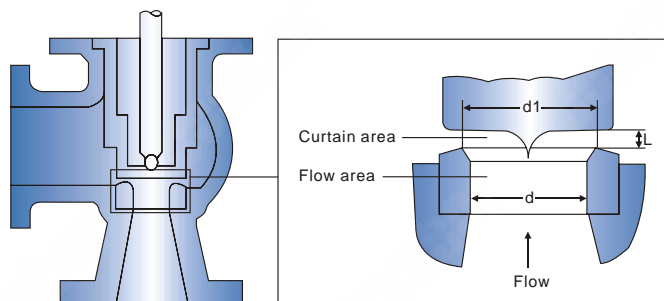
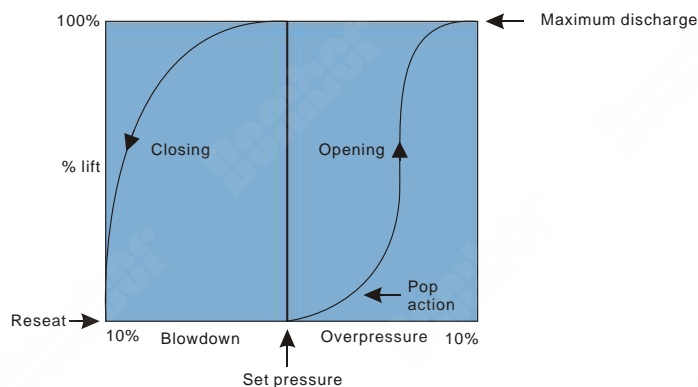

Figure a



RESEATING

Once normal operating conditions have been restored, the valve is required to close again, but since the larger area of the disc is still exposed to the fluid, the valve will not close until the pressure has dropped below the original set pressure. The difference between the set pressure and this reseating pressure is known as the 'blowdown', and it is usually specified as a percentage of the set pressure. For compressible fluids, the blowdown is usually less than 10%, and for liquids, it can be up to 20%.

THROAT DIAMETER CODE IDENTIFICATION

Code	D	E	F	G	H	J	K	L	M	N	P	Q	R
Size	10	13	16	20.5	26	33	40	50	55	60	72	96	115

MAIN PROPERTY AND SPECIFICATIONS

Normal Pressure	Class	150	300	600	900	1500	2500
Body strength	Ps (MPa)	3	7.5	15	22.5	35	38
Set pressure	Pk (MPa)	0.1~2	1.6~5	3.2~10	8~15	10~25	10~25
Seal pressure	Pm	90%Pk					
Reseating pressure	Ph	≥90%Pk					
Relieving pressure	Pp	≤1.1Pk					
Lift	H (mm)	≥1/4 do					

TYPICAL MATERIAL LIST

No.	Part Name	WCB	WC6,9	CF8	CF8M	CF3M
1	Body	WCB	WC6.WC9	CF8	CF8M	CF3M
2	Nozzle	304	304	316	316	316L
3	Plug	C.St	420	420	420	420
4	Nozzle Ring	CF8	CF8	CF8M	316	316L
5	Ser Screw	416	304	304	304	316
6	Disc	304	304	316	316	316L
7	Guide	304	304	304	316	316L
8	Disc Holder	420	420	304	316	316L
9	Spring	Alloy St	Alloy St.	Alloy St Spread Teflon	Alloy St Spread Teflon	Alloy St Spread Teflon
10	Spring Washer	C.St	C.St	420	420	420
11	Spindle	416	416	304	316	316
12	Bonnet	WCB	WC6	CF8	CF8M	CF3M
13	Adjusting Bolt	420	420	416	416	416
14	Adj. Bolt Nut	C.St	420	420	420	420
15	Cap	C.St	C.St	CF8	CF8M	CF3M
16	Nut	Steel	Steel	304	304	304
17	Bolt	Steel	Steel	304	304	304
18	Bellows	304	316L	316	316	316L
19	Gaskets	Asbestos	V1500	Teflon	Teflon	Teflon
20	Lifting Level	C.St	C.St	C.St	C.St	C.St
21	Rail	C.St	C.St	C.St	C.St	C.St
22	Upgrade Nut	C.St	C.St	C.St	C.St	C.St

OTHER MATERIALS AVAILABLE UPON REQUEST

CONVENTIONAL FULL LIFT SAFETY RELIEF VALVE

- Conventional Safety Relief Valve, Angle Pattern
- Cast steel bonnet and cap, corrosion resistant trim
- Spring Loaded, Full Lift
- Designed to ISO 4126, API Rp520

Face to Face	API 526
End Flange	ASME B16.5a
Class	ASME CL150

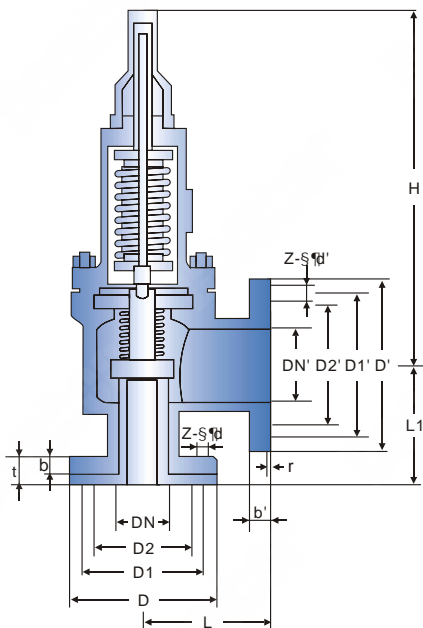

DB-A42

CONVENTIONAL FULL LIFT SAFETY RELIEF VALVE

- Conventional Safety Relief Valve, Angle Pattern
- Cast steel bonnet and cap, corrosion resistant trim
- Spring Loaded, Full Lift
- Designed to ISO 4126, API Rp520

Face to Face	API 526
End Flange	ASME B16.5a
Class	ASME CL300

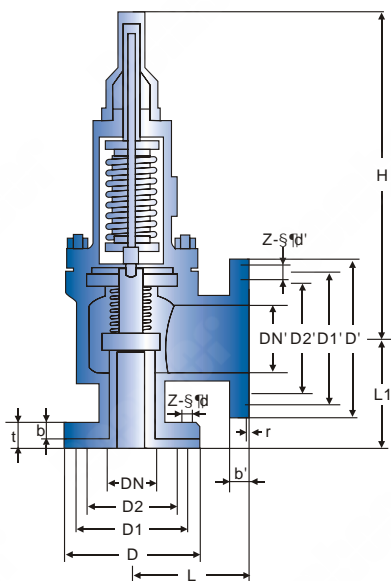

DB-A42

CLASS 150 DIMENSION

SIZE (in.)	d0	D	D1	D2	b	t	Z-Sφd'	DN'	D'
1/2"X3/4"	D	89	60.5	35	12	6	4-15	20	98
3/4"X1"	D	98	70	43	14	10	4-15	25	108
1"X1-1/2"	D	108	79.5	51	15	7	4-15	40	127
1"X2"	D	108	79.5	51	15	7	4-15	50	152
1-1/2"X2"	G	127	98.5	73	18	6	4-15	50	152
1-1/2"X2-1/2"	G	127	98.5	73	18	6	4-15	65	178
1-1/2"X3"	G	127	98.5	73	18	6	4-15	80	190
2"X2-1/2"	H	152	120.5	92	18	6	4-19	65	178
2"X3"	J	152	120.5	92	18	6	4-19	80	190
2-1/2"X4"	J	178	139.5	105	20	7	4-19	100	229
3"X4"	L	190	152.5	127	22	10	4-19	100	229
4"X6"	N	229	190.5	157	24	12	8-19	150	279
6"X8"	P	279	241.5	216	26	10	8-22	200	343
8"X10"	R	343	298.5	270	29	10	8-22	250	406
12"X14"	T	483	432	381	32	10	12-25	350	533

SIZE (in.)	D1'	D2'	b'	t'	Z-Sφd'	L	L1	H
1/2"X3/4"	70	43	14	16	4-15	90	90	260
3/4"X1"	79.5	51	15	16	4-15	96	92	280
1"X1-1/2"	98.5	73	18	16	4-15	115	105	290
1"X2"	120.5	92	18	16	4-19	115	105	290
1-1/2"X2"	120.5	92	18	16	4-19	121	124	320
1-1/2"X2-1/2"	139.5	105	20	16	4-19	121	124	340
1-1/2"X3"	152.5	127	22	16	4-19	124	130	340
2"X2-1/2"	139.5	105	20	16	4-19	124	130	360
2"X3"	152.5	127	22	16	4-19	124	130	360
2-1/2"X4"	190.5	157	24	16	8-19	143	137	360
3"X4"	190.5	157	24	16	8-19	162	156	450
4"X6"	241.5	216	26	16	8-22	229	181	510
6"X8"	298.5	270	29	16	8-22	241	240	740
8"X10"	362	324	31	16	12-25	279	276	810
12"X14"	476	413	35	16	12-28	370	360	860

CLASS 300 DIMENSION

SIZE (in.)	d0	D	D1	D2	b	t	Z-Sφd'	DN'	D'
1/2"X3/4"	D	95	66.5	35	15	6	4-15	20	98
3/4"X1"	D	117	82.5	43	16	10	4-19	25	108
1"X1-1/2"	D	124	90	51	18	7	4-19	40	127
1"X2"	D	124	90	51	18	6	4-19	50	152
1-1/2"X2"	G	156	114.5	73	20	6	4-22	50	152
1-1/2"X2-1/2"	G	156	114.5	73	20	9	4-22	65	178
1-1/2"X3"	G	156	114.5	73	20	6	4-22	80	190
2"X2-1/2"	H	165	127	92	22	6	8-19	65	178
2"X3"	J	165	127	92	22	6	8-19	80	190
2-1/2"X4"	J	190	149.5	105	24	7	8-22	100	229
3"X4"	L	210	168	127	28	10	8-22	100	229
4"X6"	N	254	200	157	32	12	8-22	150	279
6"X8"	P	318	270	216	8	10	12-22	200	343
8"X10"	R	381	330	270	42	10	12-25	250	406

SIZE (in.)	D1'	D2'	b'	t'	z-φd'	L	L1	H
1/2"X3/4"	70	43	14	1.6	4-15	90	90	260
3/4"X1"	79.5	51	15	1.6	4-15	96	92	280
1"X1-1/2"	98.5	73	18	1.6	4-15	115	105	290
1"X2"	120.5	92	18	1.6	4-19	115	105	290
1-1/2"X2"	120.5	92	18	1.6	4-19	121	124	320
1-1/2"X2-1/2"	139.5	105	20	1.6	4-19	121	124	340
1-1/2"X3"	152.5	127	22	1.6	4-19	124	130	340
2"X2-1/2"	139.5	105	20	1.6	4-19	124	130	360
2"X3"	152.5	127	22	1.6	4-19	124	130	360
2-1/2"X4"	190.5	157	24	1.6	8-19	143	137	360
3"X4"	190.5	157	24	1.6	8-19	162	156	450
4"X6"	241.5	216	26	1.6	8-22	229	181	510
6"X8"	298.5	270	29	1.6	8-22	241	240	740
8"X10"	362	324	31	1.6	12-25	279	276	810

CONVENTIONAL FULL LIFT SAFETY RELIEF VALVE

- Conventional Safety Relief Valve, Angle Pattern
- Cast steel bonnet and cap, corrosion resistant trim
- Spring Loaded, Full Lift
- Designed to ISO 4126, API Rp520

Face to Face	API 526
End Flange	ASME B16.5a
Class	ASME CL600-1500

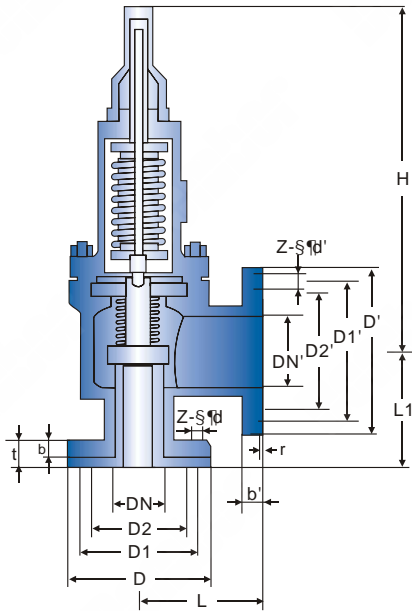

DB-A42

BALANCED SAFETY RELIEF VALVE

- Cast Steel Safety Valve, Balanced Bellow, Angle Pattern
- Spring Loaded, Auxiliary balancing piston
- Designed to ISO 4126, API Rp520

Face to Face	API 526
End Flange	ASME B16.5a
Class	ASME CL600

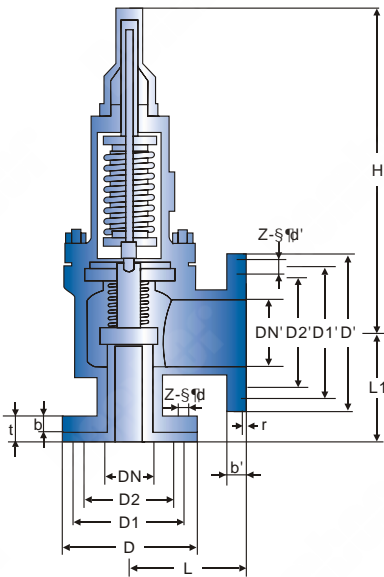

DB-WA42

CLASS 600 DIMENSION

SIZE (in.)	d0	D	D1	D2	b	t	Z-S'φd	DN'	D'	D1'	D2'	b'	t'	Z-S'φd'	L	L1	H
3/4"X1"	D	117	82.5	43	16	10	4-19	25	108	79.5	51	15	1.6	4-15	96	92	290
1"X2"	D	124	90	51	19	6	4-19	50	152	120.5	92	18	1.6	4-19	115	105	290
1-1/2"X2"	F	156	114.5	73	22	10	4-22	50	152	120.5	92	18	1.6	4-19	152	124	340
1-1/2"X2-1/2"	F	156	114.5	73	22	9	4-22	65	178	139.5	105	20	1.6	4-19	152	124	350
1-1/2"X3"	F	156	114.5	73	22	6	4-22	80	190	152.5	127	22	1.6	4-19	152	124	350
2"X2-1/2"	H	165	127	92	26	6	8-19	65	178	139.5	105	20	1.6	4-19	162	154	380
2"X3"	H	165	127	92	26	6	8-19	80	190	152.5	127	22	1.6	4-19	162	154	380
2-1/2"X4"	K	190	149.5	105	29	7	8-22	100	229	190.5	157	24	1.6	8-19	143	165	380
3"X4"	K	210	168	127	32	10	8-22	100	229	190.5	157	24	1.6	8-19	162	155	460
4"X6"	N	273	215.9	157	38	12	8-25	150	279	241.5	216	26	1.6	8-22	210	200	520
6"X8"	P	356	292	216	46	10	12-28	200	343	298.5	270	29	1.6	8-22	241	240	750

CLASS 900 DIMENSION

SIZE (INCH)	d0	D	D1	D2	b	t	Z-S'φd	DN'	D'	D1'	D2'	b'	t'	Z-S'φd'	L	L1	H
1-1/2"X2"	F	178	124	73	32	10	4-28	50	152	120.5	92	18	1.6	4-19	165	124	360
2"X3"	H	216	165.1	92	38	10	8-25	80	190	152.5	127	22	1.6	4-19	162	154	390
3"X4"	J	241	190.5	127	38	10	8-25	100	229	190.5	157	24	1.6	8-19	181	184	480
4"X6"	K	292	235	150	44	12	8-32	150	279	241.5	216	26	1.6	8-22	222	197	540

CLASS 1500 DIMENSION

SIZE (in.)	d0	D	D1	D2	b	t	Z-S'φd	DN'	D'	D1'	D2'	b'	t'	Z-S'φd'	L	L1	H
3/4"X1"	D	130	89	43	20	10	4-22	25	124	90	51	18	1.6	4-19	120	138	310
1-1/2"X2"	D	178	124	73	26	12	4-28	50	165	127	95	22	1.6	8-19	150	105	360
1-1/2"X2-1/2"	F	178	124	73	26	12	4-18	65	190	149.5	105	24	1.6	8-22	152	124	360
2"X3"	G	216	165	92	32	15	8-25	80	210	168	127	28	1.6	8-22	162	154	380
3"X4"	J	267	203.2	127	42	14	8-32	100	254	200	157	32	1.6	8-22	181	184	490

CLASS 600 DIMENSION

SIZE (in.)	d0	D	D1	D2	b	t	Z-S'φd	DN'	D'
3/4"X1"	D	117	82.5	43	16	10	4-19	25	108
1"X2"	D	124	90	51	19	6	4-19	50	152
1-1/2"X2"	F	156	114.5	73	22	10	4-22	50	152
1-1/2"X2-1/2"	F	156	114.5	73	22	9	4-22	65	178
1-1/2"X3"	F	156	114.5	73	22	6	4-22	80	190
2"X2-1/2"	H	165	127	92	26	6	8-19	65	178
2"X3"	H	165	127	92	26	6	8-19	80	190
2-1/2"X4"	K	190	149.5	105	29	7	8-22	100	229
3"X4"	K	210	168	127	32	10	8-22	100	229
4"X6"	N	273	215.9	157	38	12	8-25	150	279
6"X8"	P	356	292	216	46	10	12-28	200	343

SIZE (in.)	D1'	D2'	b'	t'	Z-S'φd'	L	L1	H
3/4"X1"	79.5	51	15	1.6	4-15	96	92	330
1"X2"	120.5	92	18	1.6	4-19	115	105	340
1-1/2"X2"	120.5	92	18	1.6	4-19	152	124	360
1-1/2"X2-1/2"	139.5	105	20	1.6	4-19	152	124	380
1-1/2"X3"	152.5	127	22	1.6	4-19	152	124	380
2"X2-1/2"	139.5	105	20	1.6	4-19	162	154	390
2"X3"	152.5	127	22	1.6	4-19	162	154	390
2-1/2"X4"	190.5	157	24	1.6	8-19	143	165	390
3"X4"	190.5	157	24	1.6	8-19	162	155	460
4"X6"	241.5	216	26	1.6	8-22	210	200	540
6"X8"	298.5	270	29	1.6	8-22	241	240	780

Note: Throat Diameter "d0" Refer to "Code Table".

CONVENTIONAL FULL LIFT SAFETY RELIEF VALVE

- Conventional Safety Relief Valve, Angle Pattern
- Cast steel bonnet and cap, corrosion resistant
- trim Spring Loaded, Full Lift
- Designed to ISO 4126, API Rp520

Face to Face	API 526
End Flange	ASME B16.5a
Class	ASME CL150

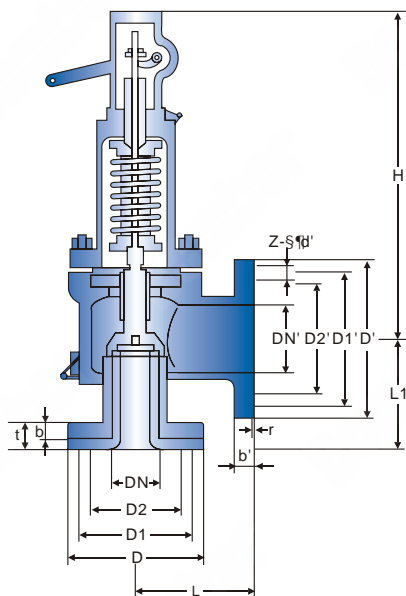

DB-A44

CONVENTIONAL FULL LIFT SAFETY RELIEF VALVE

- Conventional Safety Relief Valve, Angle Pattern
- Cast steel bonnet and cap, corrosion resistant trim
- Spring Loaded, Full Lift
- Designed to ISO 4126, API Rp520

Face to Face	API 526
End Flange	ASME B16.5a
Class	ASME CL300/600

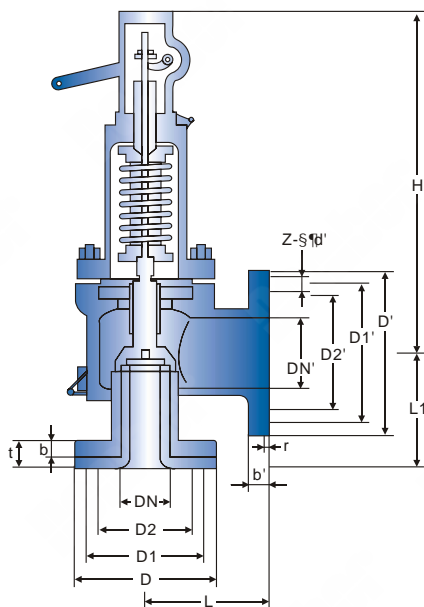

DB-A44

CLASS 150 DIMENSION

SIZE (in.)	d0	D	D1	D2	b	t	Z-S'fd	DN'	D'	D1'	D2'	b'	t'	Z-S'fd' L	L1	H	
1/2"X3/4"	D	89	60.5	35	12	18	4-15	20	98	70	43	14	1.6	4-15	90	90	260
3/4"X1"	D	98	70	43	14	24	4-15	25	108	79.5	51	15	1.6	4-15	96	92	260
1"X1-1/2"	D	108	79.5	51	15	22	4-15	40	127	98.5	73	18	1.6	4-15	115	105	280
1"X2"	D	108	79.5	51	15	22	4-15	50	152	120.5	92	18	1.6	4-19	115	105	280
1-1/2"X2"	G	127	98.5	73	18	24	4-15	50	152	120.5	92	18	1.6	4-19	121	124	310
1-1/2"X2-1/2"	G	127	98.5	73	18	24	4-15	65	178	139.5	105	20	1.6	4-19	121	124	310
1-1/2"X3"	G	127	98.5	73	18	24	4-15	80	190	152.5	127	22	1.6	4-19	124	130	310
2"X2-1/2"	H	152	120.5	92	18	24	4-19	65	178	139.5	105	20	1.6	4-19	124	130	350
2"X3"	J	152	120.5	92	18	24	4-19	80	190	152.5	127	22	1.6	4-19	124	130	350
2-1/2"X4"	J	178	139.5	105	20	27	4-19	100	229	190.5	157	24	1.6	8-19	163	137	430
3"X4"	L	190	152.5	127	22	32	4-19	100	229	190.5	157	24	1.6	8-19	162	156	490
4"X6"	N	229	190.5	157	24	36	8-19	150	279	241.5	216	26	1.6	8-22	229	181	610
6"X8"	P	279	241.5	216	26	36	8-22	200	343	298.5	270	29	1.6	8-22	241	240	840
8"X10"	R	343	298.5	270	29	39	8-22	250	406	362	324	31	1.6	12-25	279	276	990
12"X14"	T	483	432	381	32	42	12-25	350	533	476	413	35	1.6	12-28	370	360	1040

Unit:mm

Note: Throat Diameter "d0" Refer to "Code Table".

CLASS 300 DIMENSION

SIZE (in.)	d0	D	D1	D2	b	t	Z-S'fd	DN'	D'	D1'	D2'	b'	t'	Z-S'fd' L	L1	H	
1/2"X3/4"	D	95	66.5	35	15	6	4-15	20	98	70	43	14	1.6	4-15	90	90	260
3/4"X1"	D	117	82.5	43	16	10	4-19	25	108	79.5	51	15	1.6	4-15	96	92	260
1"X1-1/2"	D	124	90	51	18	7	4-19	40	127	98.5	73	18	1.6	4-15	115	105	280
1"X2"	D	124	90	51	18	6	4-19	50	152	120.5	92	18	1.6	4-19	115	105	20
1-1/2"X2"	F	156	114.5	73	20	6	4-22	50	152	120.5	92	18	1.6	4-19	121	124	310
1-1/2" "X2-1/2"	F	156	114.5	73	20	9	4-22	65	178	139.5	105	20	1.6	4-19	121	124	310
1-1/2"X3"	F	156	114.5	73	20	6	4-22	80	190	152.5	127	22	1.6	4-19	124	130	310
2"X2-1/2"	H	165	127	92	22	6	8-19	65	178	139.5	105	20	1.6	4-19	124	130	350
2"X3"	H	165	127	92	22	6	8-19	80	190	152.5	127	22	1.6	4-19	124	130	350
2-1/2"X4"	J	190	149.5	105	24	7	8-22	100	229	190.5	157	24	1.6	8-19	143	137	430
3"X4"	L	210	168	127	28	10	8-22	100	229	190.5	157	24	1.6	8-19	162	156	490
4"X6"	N	254	200	157	32	12	8-22	150	279	241.5	216	26	1.6	8-22	229	181	610
6"X8"	P	318	270	216	8	10	12-22	200	343	298.5	270	29	1.6	8-22	241	240	840
8"X10"	R	381	330	270	42	10	12-25	250	406	362	324	31	1.6	12-25	279	276	990
10"X12"	T	445	387.5	324	46	10	16-28	350	533	476	413	35	1.6	12-25	350	330	1040

Unit: mm

Note: Throat Diameter "d0" Refer to "Code Table".

CLASS 600 DIMENSION

SIZE (in.)	d0	D	D1	D2	b	t	Z-S'fd	DN'	D'	D1'	D2'	b'	t'	Z-S'fd' L	L1	H	
3/4"X1"	D	117	82.5	43	16	10	4-19	25	108	79.5	51	15	1.6	4-15	96	92	280
1"X2"	D	124	90	51	19	6	4-19	50	152	120.5	92	18	1.6	4-19	115	105	300
1-1/2"X2"	F	156	114.5	73	22	10	4-22	50	152	120.5	92	18	1.6	4-19	152	124	300
1-1/2"X2-1/2"	F	156	114.5	73	22	9	4-22	65	178	139.5	105	20	1.6	4-19	152	124	330
1-1/2"X3"	F	156	114.5	73	22	6	4-22	80	190	152.5	127	22	1.6	4-19	152	124	330
2"X2-1/2"	H	165	127	92	26	6	8-19	65	178	139.5	105	20	1.6	4-19	162	154	330
2"X3"	H	165	127	92	26	6	8-19	80	190	152.5	127	22	1.6	4-19	162	154	360
2-1/2"X4"	K	190	149.5	105	29	7	8-22	100	229	190.5	157	24	1.6	8-19	143	165	360
3"X4"	K	210	168	127	32	10	8-22	100	229	190.5	157	24	1.6	8-19	162	155	440
4"X6"	N	273	215.9	157	38	12	8-25	150	279	241.5	216	26	1.6	8-22	210	200	610
6"X8"	P	356	292	216	46	10	12-28	200	343	298.5	270	29	1.6	8-22	241	240	625

Unit: mm

Note: Throat Diameter "d0" Refer to "Code Table".

CONVENTIONAL FULL LIFT SAFETY RELIEF VALVE

- Conventional Safety Relief Valve, Angle Pattern
- Cast steel bonnet and cap, corrosion resistant trim
- Spring Loaded, Full Lift
- Designed to ISO 4126, API Rp520

Face to Face	API 526
End Flange	ASME B16.5a
Class	ASME CL150

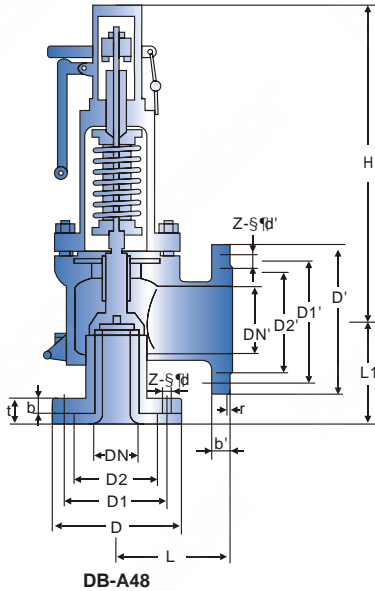

CLASS 150 DIMENSION

SIZE (in.)	d0	D	D1	D2	b	t	Z-S'f'd	DN'	D'	D1'	D2'	b'	t'	Z-S'f'd'	L	L1	H
Unit: mm																	
1/2"X3/4"	D	89	60.5	35	12	6	4-15	20	98	70	43	14	1.6	4-15	90	90	290
3/4"X1"	D	98	70	43	14	6	4-15	25	108	79.5	51	15	1.6	4-15	96	92	310
1"X1-1/2"	D	108	79.5	51	15	7	4-15	40	127	98.5	73	18	1.6	4-15	115	105	320
1"X2"	D	108	79.5	51	15	7	4-15	50	152	120.5	92	18	1.6	4-19	115	105	320
1-1/2"X2"	G	127	98.5	73	18	6	4-15	50	152	120.5	92	18	1.6	4-19	121	124	350
1-1/2"X2-1/2"	G	127	98.5	73	18	6	4-15	65	178	139.5	105	20	1.6	4-19	121	124	360
1-1/2"X3"	G	127	98.5	73	18	6	4-15	80	190	152.5	127	22	1.6	4-19	124	130	360
2"X2-1/2"	H	152	120.5	92	18	6	4-19	65	178	139.5	105	20	1.6	4-19	124	130	380
2"X3"	J	152	120.5	92	18	6	4-19	80	190	152.5	127	22	1.6	4-19	124	130	380
2-1/2"X4"	J	178	139.5	105	20	7	4-19	100	229	190.5	157	24	1.6	8-19	163	137	380
3"X4"	L	190	152.5	127	22	10	4-19	100	229	190.5	157	24	1.6	8-19	162	156	480
4"X6"	N	229	190.5	157	24	12	8-19	150	279	241.5	216	26	1.6	8-22	229	181	540
6"X8"	P	279	241.5	216	26	10	8-22	200	343	298.5	270	29	1.6	8-22	241	240	760
8"X10"	R	343	298.5	270	29	10	8-22	250	406	362	324	31	1.6	12-25	279	276	830
12"X14"	T	483	432	381	32	10	12-25	350	533	476	413	35	1.6	12-28	370	360	890

Note: Throat Diameter "d0" Refer to "Code Table".

CONVENTIONAL FULL LIFT SAFETY RELIEF VALVE

- Conventional Safety Relief Valve, Angle Pattern
- Cast steel bonnet and cap, corrosion resistant trim
- Spring Loaded, Full Lift
- Designed to ISO 4126, API Rp520

Face to Face	API 526
End Flange	ASME B16.5a
Class	ASME CL150

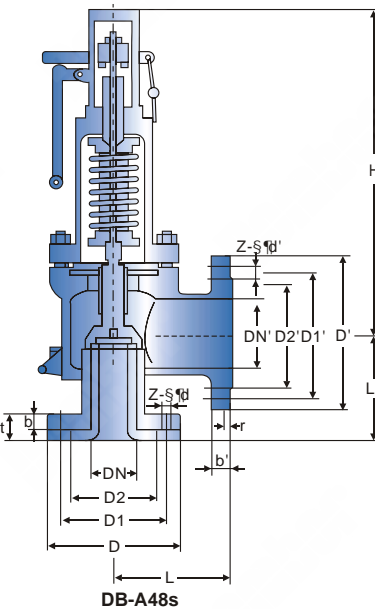

CLASS 150 DIMENSION

SIZE (in.)	d0	D	D1	D2	b	t	Z-S'f'd	DN'	D'	D1'	D2'	b'	t'	Z-S'f'd'	L	L1	H
Unit: mm																	
1/2"X3/4"	D	89	60.5	35	12	6	4-15	20	98	70	43	14	1.6	4-15	90	90	380
3/4"X1"	D	98	70	43	14	8	4-15	25	108	79.5	51	15	1.6	4-15	96	92	390
1"X1-1/2"	D	108	79.5	51	15	7	4-15	40	127	98.5	73	18	1.6	4-15	115	105	395
1"X2"	D	108	79.5	51	15	7	4-15	50	152	120.5	92	18	1.6	4-19	115	105	395
1-1/2"X2"	G	127	98.5	73	18	6	4-15	50	152	120.5	92	18	1.6	4-19	121	124	420
1-1/2"X2-1/2"	G	127	98.5	73	18	6	4-15	65	178	139.5	105	20	1.6	4-19	121	124	420
1-1/2"X3"	G	127	98.5	73	18	6	4-15	80	190	152.5	127	22	1.6	4-19	124	130	430
2"X2-1/2"	H	152	120.5	92	18	6	4-19	65	178	139.5	105	20	1.6	4-19	124	130	460
2"X3"	J	152	120.5	92	18	6	4-19	80	190	152.5	127	22	1.6	4-19	124	130	460
2-1/2"X4"	J	178	139.5	105	20	7	4-19	100	229	190.5	157	24	1.6	8-19	143	137	480
3"X4"	L	190	152.5	127	22	10	4-19	100	229	190.5	157	24	1.6	8-19	162	156	530
4"X6"	N	229	190.5	157	24	12	8-19	150	279	241.5	216	26	1.6	8-22	229	181	610
6"X8"	P	279	241.5	216	26	10	8-22	200	343	298.5	270	29	1.6	8-22	241	240	780
8"X10"	R	343	298.5	270	29	10	8-22	250	406	362	324	31	1.6	12-25	279	276	840
12"X14"	T	483	432	381	32	10	12-25	350	533	476	413	35	1.6	12-28	370	360	980

Note: Throat Diameter "d0" Refer to "Code Table".

CLASS 300 DIMENSION

SIZE (in.)	d0	D	D1	D2	b	t	Z- $\frac{S}{t}d$	DN'	D'	D1'	D2'	b'	t'	Z- $\frac{S}{t}d'$	L	L1	H
1/2"X3/4"	D	95	66.5	35	15	6	4-15	20	98	70	43	14	1.6	4-15	90	90	380
3/4"X1"	D	117	82.5	43	16	10	4-19	25	108	79.5	51	15	1.6	4-15	96	92	390
1"X1-1/2"	D	124	90	51	18	7	4-19	40	127	98.5	73	18	1.6	4-15	115	105	395
1"X2"	D	124	90	51	18	6	4-19	50	152	120.5	92	18	1.6	4-19	115	105	395
1-1/2"X2"	F	156	114.5	73	20	6	4-22	50	152	120.5	92	18	1.6	4-19	121	124	420
1-1/2" X2-1/2"	F	156	114.5	73	20	9	4-22	65	178	139.5	105	20	1.6	4-19	121	124	420
1-1/2"X3"	F	156	114.5	73	20	6	4-22	80	190	152.5	127	22	1.6	4-19	124	130	430
2"X2-1/2"	H	165	127	92	22	6	8-19	65	178	139.5	105	20	1.6	4-19	124	130	460
2"X3"	H	165	127	92	22	6	8-19	80	190	152.5	127	22	1.6	4-19	124	130	460
2-1/2"X4"	J	190	149.5	105	24	7	8-22	100	229	190.5	157	24	1.6	8-19	143	137	480
3"X4"	L	210	168	127	28	10	8-22	100	229	190.5	157	24	1.6	8-19	162	156	430
4"X6"	N	254	200	157	32	12	8-22	150	279	241.5	216	26	1.6	8-22	229	181	610
6"X8"	P	318	270	216	40	15	12-22	200	343	298.5	270	29	1.6	8-22	241	240	780
8"X10"	Q	381	330	270	42	10	12-25	250	406	362	324	31	1.6	12-25	279	276	840

Note: Throat Diameter "d0" Refer to "Code Table".

CLASS 600 DIMENSION

SIZE (in.)	d0	D	D1	D2	b	t	Z- $\frac{S}{t}d$	DN'	D'	D1'	D2'	b'	t'	Z- $\frac{S}{t}d'$	L	L1	H
3/4"X1"	D	117	82.5	43	16	10	4-19	25	108	79.5	51	15	1.6	4-15	96	92	400
1"X2"	D	124	90	51	19	6	4-19	50	152	120.5	92	18	1.6	4-19	115	105	420
1-1/2"X2"	F	156	114.5	73	22	10	4-22	50	152	120.5	92	18	1.6	4-19	152	124	440
1-1/2"X2-1/2"	F	156	114.5	73	22	9	4-22	65	178	139.5	105	20	1.6	4-19	152	124	440
1-1/2"X3"	F	156	114.5	73	22	6	4-22	80	190	152.5	127	22	1.6	4-19	152	124	450
2"X2-1/2"	H	165	127	92	26	6	8-19	65	178	139.5	105	20	1.6	4-19	162	154	480
2"X3"	H	165	127	92	26	6	8-19	80	190	152.5	127	22	1.6	4-19	162	154	480
2-1/2"X4"	K	190	149.5	105	29	7	8-22	100	229	190.5	157	24	1.6	8-19	143	165	490
3"X4"	K	210	168	127	32	10	8-22	100	229	190.5	157	24	1.6	8-19	162	155	540
4"X6"	N	273	215.9	157	38	12	8-25	150	279	241.5	216	26	1.6	8-22	210	200	620
6"X8"	R	356	292	216	46	10	12-28	200	343	298.5	270	29	1.6	8-22	241	240	790

Note: Throat Diameter "d0" Refer to "Code Table".

CLASS 900 DIMENSION

SIZE (in.)	d0	D	D1	D2	b	t	Z- $\frac{S}{t}d$	DN'	D'	D1'	D2'	b'	t'	Z- $\frac{S}{t}d'$	L	L1	H
1-1/2"X2"	F	178	124	73	32	10	4-28	50	152	120.5	92	18	1.6	4-19	165	124	440
2"X3"	H	216	165.1	92	38	10	8-25	80	190	152.5	127	22	1.6	4-19	162	154	480
3"X4"	J	241	190.5	127	38	10	8-25	100	229	190.5	157	24	1.6	8-19	181	184	550
4"X6"	K	292	235	150	44	12	8-32	150	279	241.5	216	26	1.6	8-22	222	197	630

Note: Throat Diameter "d0" Refer to "Code Table".

CLASS 1500 DIMENSION

SIZE (in.)	d0	D	D1	D2	b	t	Z- $\frac{S}{t}d$	DN'	D'	D1'	D2'	b'	t'	Z- $\frac{S}{t}d'$	L	L1	H
1"X1/2"	D	150	101.6	51	28	15	4-25	40	156	114.5	73	20	1.6	4-22	125	125	420
1-1/2"X1-1/2"	E	178	124	73	32	14	4-28	40	156	114.5	73	20	1.6	4-22	150	194	450
1-1/2"X2"	E	178	124	73	32	15	4-18	50	165	127	92	22	1.6	8-19	150	194	450
1-1/2"X3"	E	178	124	73	41	7	4-29	80	210	268.5	127	31	1.6	8-22	155	254	450

Note: Throat Diameter "d0" Refer to "Code Table".

CLASS 2500 DIMENSION

SIZE (in.)	d0	D	D1	D2	b	t	Z- $\frac{S}{t}d$	DN'	D'	D1'	D2'	b'	t'	Z- $\frac{S}{t}d'$	L	L1	H
1-1/2"X2-1/2"	F	205	146	73	45	7	4-32	65	190	149	105	27	1.6	8-22	165	140	670

Note: Throat Diameter "d0" Refer to "Code Table".

CONVENTIONAL LOW LIFT SAFETY RELIEF VALVE

- Conventional Safety Relief Valve, Angle Pattern
- Cast Steel Bonnet and Cap, Corrosion Resistant Trim
- Spring Loaded, Low Lift
- Designed to ISO4126, API Rp520

Face to Face	API 526
End Flange	ASME B16.5a
Class	ASME CL150/300

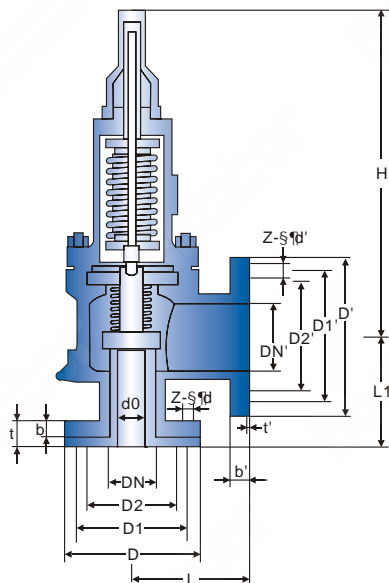

DB-A41

CONVENTIONAL LOW LIFT SAFETY RELIEF VALVE

- Conventional Safety Relief Valve, Angle Pattern
- Cast Steel Bonnet and Cap, Corrosion Resistant Trim
- Spring Loaded, Low Lift
- Designed to ISO4126, API Rp520

Face to Face	API 526
End Flange	ASME B16.5a
Class	ASME CL600/900

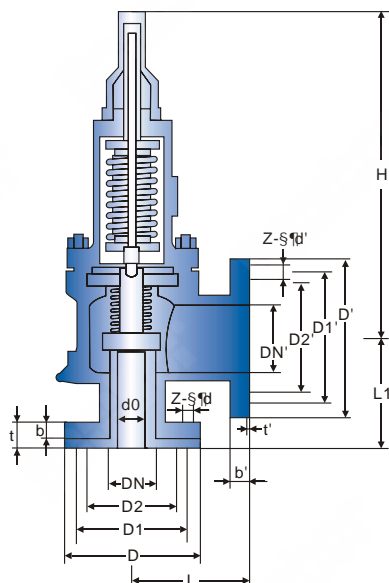

DB-A41

CLASS 150 DIMENSION

SIZE (in.)	d0	D	D1	D2	b	t	Z-§1d	DN'	D'	D1'	D2'	b'	t'	Z-§1d'	L	L1	H
1/2"X1/2"	D	89	60.5	35	12	6	4-15	15	89	60.5	35	1.6	12	4-15	90	90	260
3/4"X1"	D	98	70	43	14	6	4-15	25	108	79.5	51	1.6	15	4-15	96	92	280
1"X1"	D	108	79.5	51	15	9	4-15	25	108	79.5	51	1.6	15	4-15	100	100	290
1"X2"	E	108	79.5	51	15	9	4-15	50	152	120.5	92	1.6	18	4-15	114	105	290
1-1/2"X2"	G	127	98.5	73	18	10	4-15	40	127	98.5	73	1.6	18	4-15	110	115	330
1-1/2"X3"	G	127	98.5	73	18	10	4-15	50	152	120.5	92	1.6	18	4-19	110	115	330
2"X3"	J	152	120.5	92	18	10	4-19	80	190	152.5	127	1.6	22	4-19	124	130	330

Note: Throat Diameter "d0" Refer to "Code Table".

CLASS 300 DIMENSION

SIZE (in.)	d0	D	D1	D2	b	t	Z-§1d	DN'	D'	D1'	D2'	b'	t'	Z-§1d'	L	L1	H
1/2"X1/2"	D	95	66.5	35	15	6	4-15	15	89	60.5	35	1.6	12	4-15	90	90	260
3/4"X1"	D	117	82.5	43	16	10	4-19	25	108	79.5	51	1.6	15	4-15	96	92	280
1"X1"	D	124	90	51	18	6	4-19	25	108	79.5	51	1.6	15	4-15	100	100	290
1"X2"	E	124	90	51	18	6	4-19	50	152	120.5	92	1.6	18	4-19	114	105	290
1-1/2"X1-1/2"	G	156	114.5	73	20	9	4-22	40	127	98.5	73	1.6	18	4-15	110	115	330
1-1/2"X2"	G	156	114.5	73	20	9	4-22	50	152	120.5	92	1.6	18	4-19	110	115	330
2"X3"	J	165	127	92	22	8	8-19	80	190	152.5	127	1.6	22	4-19	124	130	350

Note: Throat Diameter "d0" Refer to "Code Table".

CLASS 600 DIMENSION

SIZE (in.)	d0	D	D1	D2	b	t	Z-§1d	DN'	D'	D1'	D2'	b'	t'	Z-§1d'	L	L1	H
3/4"X1"	D	117	82.5	43	16	10	4-19	25	108	79.5	51	1.6	15	4-15	96	92	400
1"X2"	D	124	90	51	19	6	4-19	50	152	120.5	92	1.6	18	4-19	115	105	420
1-1/2"X1-1/2"	F	156	114.5	73	22	10	4-22	50	152	120.5	92	1.6	18	4-19	152	124	440
1-1/2"X2"	F	156	114.5	73	22	9	4-22	65	178	139.5	105	20	1.6	4-19	152	124	440

Note: Throat Diameter "d0" Refer to "Code Table".

CLASS 900 DIMENSION

SIZE (in.)	d0	D	D1	D2	b	t	Z-§1d	DN'	D'	D1'	D2'	b'	t'	Z-§1d'	L	L1	H
1"X1-1/2"	D	150	101.6	51	28	15	4-25	40	156	114.5	73	20	1.6	4-22	125	125	320
1-1/2"X1-1/2"	F	178	124	73	32	14	4-28	40	156	114.5	73	20	1.6	4-22	150	194	350
1-1/2"X2"	F	178	124	73	32	15	4-28	50	165	127	92	22	1.6	8-19	140	105	350

Note: Throat Diameter "d0" Refer to "Code Table".

BALANCED BELLOW SAFETY RELIEF VALVE

- Cast Steel Safety Valve, Balanced Bellow, Angle Pattern
- Spring Loaded, Auxiliary balancing piston
- Designed to ISO 4126, API Rp520

Face to Face	API 526
End Flange	ASME B16.5a
Class	ASME CL150/300

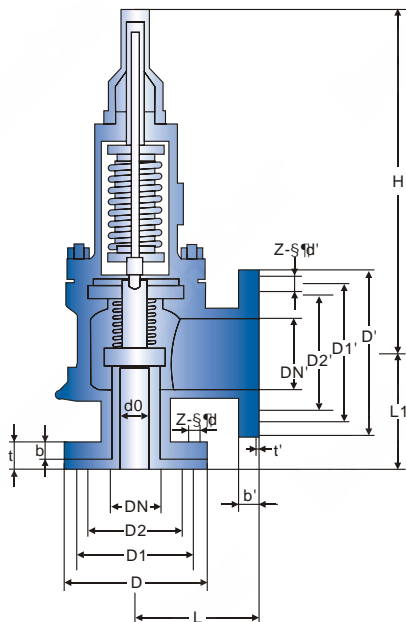

DB-WA41

BALANCED SAFETY RELIEF VALVE

- Cast Steel Safety Valve, Balanced Bellow, Angle Pattern
- Spring Loaded, Auxiliary balancing piston
- Designed to ISO 4126, API Rp520

Face to Face	API 526
End Flange	ASME B16.5a
Class	ASME CL150/300

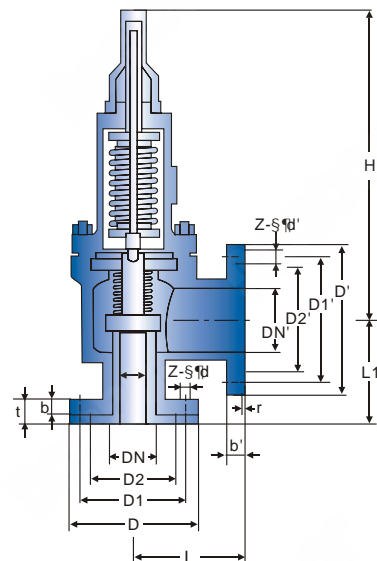

DB-WA42

CLASS 150 DIMENSION

SIZE (in.)	d0	D	D1	D2	b	t	Z-S'fd'	DN'	D'	D1'	D2'	B'	t'	Z-S'fd'	L	L1	H
1/2"X1/2"	D	89	60.5	35	12	6	4-15	15	89	60.5	35	1.6	12	4-15	90	90	320
3/4"X1"	D	98	70	43	14	6	4-15	25	108	79.5	51	1.6	15	4-15	96	92	330
1"X1"	D	108	79.5	51	15	9	4-15	25	108	79.5	51	1.6	15	4-15	100	100	350
1"X2"	E	108	79.5	51	15	9	4-15	50	152	120.5	92	1.6	18	4-19	114	105	350
1-1/2"X1-1/2"	G	127	98.5	73	18	10	4-15	40	127	98.5	73	1.6	18	4-15	110	115	370
1-1/2"X2"	G	127	98.5	73	18	10	4-15	50	152	120.5	92	1.6	18	4-19	110	115	370
2"X3"	J	152	120.5	92	18	10	4-19	80	190	152.5	127	1.6	22	4-19	124	130	390

Note: Throat Diameter "d0" Refer to "Code Table".

CLASS 300 DIMENSION

SIZE (in.)	d0	D	D1	D2	b	t	Z-S'fd'	DN'	D'	D1'	D2'	B'	t'	Z-S'fd'	L	L1	H
1/2"X1/2"	D	95	66.5	35	15	6	4-15	20	15	89	60.5	1.6	12	4-15	90	90	320
3/4"X1"	D	117	82.5	43	16	10	4-19	25	25	108	79.5	1.6	15	4-15	96	92	330
1"X1"	D	124	90	51	18	7	4-19	40	25	108	79.5	1.6	15	4-15	100	100	350
1"X2"	E	124	90	51	18	6	4-19	50	50	152	120.5	1.6	18	4-19	114	105	351
1-1/2"X1-1/2"	G	156	114.5	73	20	6	4-22	50	40	127	98.5	1.6	18	4-15	110	115	370
1-1/2"X2"	G	156	114.5	73	20	9	4-22	65	50	152	120.5	1.6	18	4-19	110	115	370
2"X3"	J	165	127	92	22	6	8-19	80	80	190	152.5	1.6	22	4-19	124	130	390

Note: Throat Diameter "d0" Refer to "Code Table".

CLASS 150 DIMENSION

SIZE (in.)	d0	D	D1	D2	b	t	Z-S'fd'	DN'	D'	D1'	D2'	b	t'	Z-S'fd'	L	L1	H
1/2"X3/4"	D	89	60.5	35	12	6	4-15	20	98	70	43	14	1.6	4-15	90	90	320
3/4"X1"	D	98	70	43	14	8	4-15	25	108	79.5	51	15	1.6	4-15	96	92	330
1"X1-1/2"	D	108	79.5	51	15	7	4-15	40	127	98.5	73	18	1.6	4-15	115	105	340
1"X2"	D	108	79.5	51	15	7	4-15	50	152	120.5	92	18	1.6	4-15	115	105	340
1-1/2"X2"	G	127	98.5	73	18	6	4-15	50	152	120.5	92	18	1.6	4-15	121	124	360
1-1/2"X2-1/2"	G	127	98.5	73	18	6	4-15	65	178	139.5	105	20	1.6	4-15	121	124	380
1-1/2"X3"	G	127	98.5	73	18	6	4-15	80	190	152.5	127	22	1.6	4-15	124	130	380
2"X2-1/2"	H	152	120.5	92	18	6	4-19	65	178	139.5	105	20	1.6	4-19	124	130	390
2"X3"	J	152	120.5	92	18	6	4-19	80	190	152.5	127	22	1.6	4-19	124	130	390
2-1/2"X4"	J	178	139.5	105	20	7	4-19	100	229	190.5	157	24	1.6	8-19	143	137	390
3"X4"	L	190	152.5	127	22	10	4-19	100	229	190.5	157	24	1.6	8-19	162	156	460
4"X6"	N	229	190.5	157	24	12	8-19	150	279	241.5	216	26	1.6	8-22	229	181	540
6"X8"	P	279	241.5	216	26	10	8-22	200	343	298.5	270	29	1.6	8-22	241	240	780
8"X10"	R	343	298.5	270	29	10	8-22	250	406	362	324	31	1.6	12-25	279	276	820
12"X14"	T	483	432	381	32	12	12-25	350	533	476	413	35	1.6	12-28	370	360	890

Note: Throat Diameter "d0" Refer to "Code Table".

CLASS 300 DIMENSION

SIZE (in.)	d0	D	D1	D2	b	t	Z-S'fd'	DN'	D'	D1'	D2'	b'	t'	Z-S'fd'	L	L1	H
1/2"X3/4"	D	95	66.5	35	15	6	4-15	20	98	70	43	14	1.6	4-15	90	90	320
3/4"X1"	D	117	82.5	43	16	10	4-19	25	108	79.5	51	15	1.6	4-15	96	92	330
1"X1-1/2"	D	124	90	51	18	7	4-19	40	127	98.5	73	18	1.6	4-15	115	105	340
1"X2"	D	124	90	51	18	6	4-19	50	152	120.5	92	18	1.6	4-19	115	105	340
1-1/2"X2"	F	156	114.5	73	20	6	4-22	50	152	120.5	92	18	1.6	4-19	121	124	360
1-1/2" X2-1/2" F	F	156	114.5	73	20	9	4-22	65	178	139.5	105	20	1.6	4-19	121	124	380
1-1/2"X3"	F	156	114.5	73	20	6	4-22	80	190	152.5	127	22	1.6	4-19	124	130	380
2"X2-1/2"	H	165	127	92	22	6	8-19	65	178	139.5	105	20	1.6	4-19	124	130	390
2"X3"	H	165	127	92	22	6	8-19	80	190	152.5	127	22	1.6	4-19	124	130	390
2-1/2"X4"	J	190	149.5	105	24	7	8-22	100	229	190.5	157	24	1.6	8-19	143	137	390
3"X4"	L	210	168	127	28	10	8-22	100	229	190.5	157	24	1.6	8-19	162	156	460
4"X6"	N	254	200	157	32	12	8-22	150	279	241.5	216	26	1.6	8-22	229	181	540
6"X8"	P	318	270	216	8	10	12-22	200	343	298.5	270	29	1.6	8-22	241	240	780
8"X10"	R	381	330	270	42	10	12-25	250	406	362	324	31	1.6	12-25	279	276	820
10"X12"	T	445	387.5	324	46	10	16-28	350	533	476	413	35	1.6	12-25	350	330	890

Note: Throat Diameter "d0" Refer to "Code Table".

BALANCED SAFETY RELIEF VALVE

- Cast Steel Safety Valve, Balanced Bellow, Angle Pattern
- Spring Loaded, Auxiliary balancing piston
- Designed to ISO4126, API Rp520

Face to Face	API 526
End Flange	ASME B16.5a
Class	ASME CL150/300

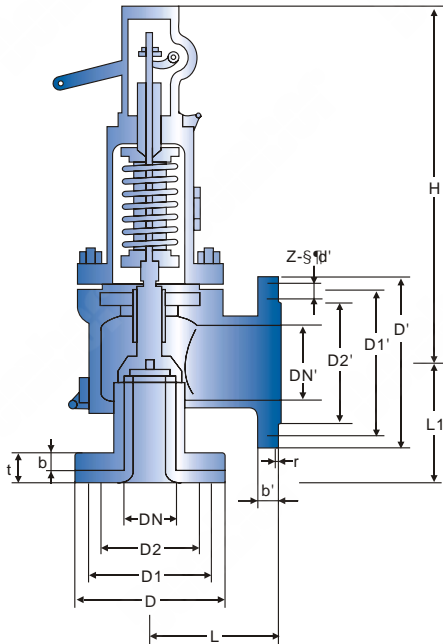

DB-WA44

BALANCED SAFETY RELIEF VALVE

- Cast Steel Safety Valve, Balanced Bellow, Angle Pattern
- Spring Loaded, Auxiliary balancing piston
- Designed to ISO4126, API Rp520

Face to Face	API 526
End Flange	ASME B16.5a
Class	ASME CL600/900

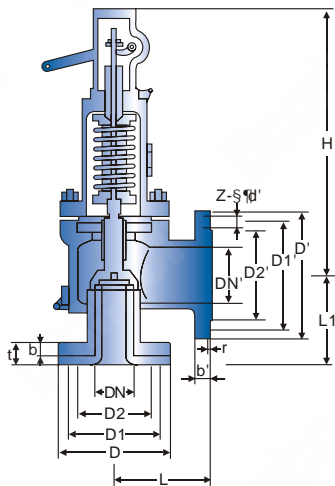

DB-WA44

CLASS 150 DIMENSION

SIZE (in.)	d0	D	D1	D2	b	t	Z-S'f'd'	DN'	D'	D1'	D2'	b'	t'	Z-S'f'd'	L	L1	H
Unit: mm																	
1/2"X3/4"	D	89	60.5	35	12	6	4-15	20	98	70	43	14	1.6	4-15	90	90	340
3/4"X1"	D	98	70	43	14	6	4-15	25	108	79.5	51	15	1.6	4-15	96	92	350
1"X1-1/2"	D	108	79.5	51	15	7	4-15	40	127	98.5	73	18	1.6	4-15	115	105	360
1"X2"	D	108	79.5	51	15	7	4-15	50	152	120.5	92	18	1.6	4-19	115	105	360
1-1/2"X2"	G	127	98.5	73	18	6	4-15	50	152	120.5	92	18	1.6	4-19	121	124	380
1-1/2"X2-1/2"	G	127	98.5	73	18	6	4-15	65	178	139.5	105	20	1.6	4-19	121	124	390
1-1/2"X3"	G	127	98.5	73	18	6	4-15	80	190	152.5	127	22	1.6	4-19	124	130	390
2"X2-1/2"	H	152	120.5	92	18	6	4-19	65	178	139.5	105	20	1.6	4-19	124	130	410
2"X3"	J	152	120.5	92	18	6	4-19	80	190	152.5	127	22	1.6	4-19	124	130	410
2-1/2"X4"	J	178	139.5	105	20	7	4-19	100	229	190.5	157	24	1.6	8-19	163	137	410
3"X4"	L	190	152.5	127	22	10	4-19	100	229	190.5	157	24	1.6	8-19	162	156	480
4"X6"	N	229	190.5	157	24	12	8-19	150	279	241.5	216	26	1.6	8-22	229	181	560
6"X8"	P	279	241.5	216	26	10	8-22	200	343	298.5	270	29	1.6	8-22	241	240	790
8"X10"	R	343	298.5	270	29	10	8-22	250	406	362	324	31	1.6	12-25	279	276	840
12"X14"	T	483	432	381	32	10	12-25	350	533	476	413	35	1.6	12-28	370	360	920

Note: Throat Diameter "d0" Refer to "Code Table".

CLASS 300 DIMENSION

SIZE (in.)	d0	D	D1	D2	b	t	Z-S'f'd'	DN'	D'	D1'	D2'	b'	t'	Z-S'f'd'	L	L1	H
Unit: mm																	
1/2"X3/4"	D	95	66.5	35	15	6	4-15	20	98	70	43	14	1.6	4-15	90	90	340
3/4"X1"	D	117	82.5	43	16	10	4-19	25	108	79.5	51	15	1.6	4-15	96	92	350
1"X1-1/2"	D	124	90	51	18	7	4-19	40	127	98.5	73	18	1.6	4-15	115	105	360
1"X2"	D	124	90	51	18	6	4-19	50	152	120.5	92	18	1.6	4-19	115	105	360
1-1/2"X2"	F	156	114.5	73	20	6	4-22	50	152	120.5	92	18	1.6	4-19	121	124	380
1-1/2" X2-1/2"	F	156	114.5	73	20	9	4-22	65	178	139.5	105	20	1.6	4-19	121	124	390
1-1/2"X3"	F	156	114.5	73	20	6	4-22	80	190	152.5	127	22	1.6	4-19	124	130	390
2"X2-1/2"	H	165	127	92	22	6	8-19	65	178	139.5	105	20	1.6	4-19	124	130	410
2"X3"	H	165	127	92	22	6	8-19	80	190	152.5	127	22	1.6	4-19	124	130	410
2-1/2"X4"	J	190	149.5	105	24	7	8-22	100	229	190.5	157	24	1.6	8-19	143	137	420
3"X4"	L	210	168	127	28	10	8-22	100	229	190.5	157	24	1.6	8-19	162	156	480
4"X6"	N	254	200	157	32	12	8-22	150	279	241.5	216	26	1.6	8-22	229	181	560
6"X8"	P	318	270	216	8	10	12-22	200	343	298.5	270	29	1.6	8-22	241	240	790
8"X10"	R	381	330	270	42	10	12-25	250	406	362	324	31	1.6	12-25	279	276	840

Note: Throat Diameter "d0" Refer to "Code Table".

CLASS 600 DIMENSION

SIZE (in.)	d0	D	D1	D2	b	t	Z-S'f'd'	DN'	D'	D1'	D2'	b'	t'	Z-S'f'd'	L	L1	H
Unit: mm																	
3/4"X1"	D	117	82.5	43	16	10	4-19	25	108	79.5	51	15	1.6	4-15	96	92	360
1"X2"	D	124	90	51	19	6	4-19	50	152	120.5	92	18	1.6	4-19	115	105	370
1-1/2"X2"	F	156	114.5	73	22	10	4-22	50	152	120.5	92	18	1.6	4-19	152	124	370
1-1/2"X2-1/2"	F	156	114.5	73	22	9	4-22	65	178	139.5	105	20	1.6	4-19	152	124	390
1-1/2"X3"	F	156	114.5	73	22	6	4-22	80	190	152.5	127	22	1.6	4-19	152	124	400
2"X2-1/2"	H	165	127	92	26	6	8-19	65	178	139.5	105	20	1.6	4-19	162	154	400
2"X3"	H	165	127	92	26	6	8-19	80	190	152.5	127	22	1.6	4-19	162	154	420
2-1/2"X4"	K	190	149.5	105	29	7	8-22	100	229	190.5	157	24	1.6	8-19	143	165	420
3"X4"	K	210	168	127	32	10	8-22	100	229	190.5	157	24	1.6	8-19	162	155	480
4"X6"	N	273	215.9	157	38	12	8-25	150	279	241.5	216	26	1.6	8-22	210	200	560
6"X8"	P	356	292	216	46	10	12-28	200	343	298.5	270	29	1.6	8-22	241	240	790

Note: Throat Diameter "d0" Refer to "Code Table".

CLASS 900 DIMENSION

SIZE (in.)	d0	D	D1	D2	b	t	Z-S'f'd'	DN'	D'	D1'	D2'	B'	t'	Z-S'f'd'	L	L1	H
Unit: mm																	
1-1/2"X2"	F	178	124	73	32	10	4-28	50	152	120.5	92	18	1.6	4-19	165	124	380
2"X3"	H	216	165.1	92	38	10	8-25	80	190	152.5	127	22	1.6	4-19	162	154	420
3"X4"	J	241	190.5	127	38	10	8-25	100	229	190.5	157	24	1.6	8-19	181	184	480
4"X6"	K	292	235	150	44	12	8-32	150	279	241.5	216	26	1.6	8-22	222	197	560

Note: Throat Diameter "d0" Refer to "Code Table".

JACKETED SAFETY RELIEF VALVE

- Cast Steel Safety Valve, Balanced Bellow, Angle Pattern
- Spring Loaded, Auxiliary balancing piston
- Designed to ISO 4126, API Rp520

Face to Face	API 526
End Flange	ASME B16.5a
Class	ASME CL150

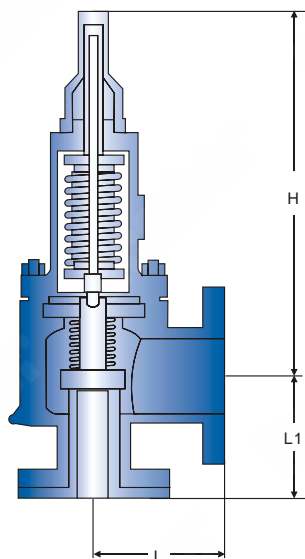

DB-J

CLASS 150 DIMENSION

SIZE (in.)	L	L1	H
3/4"X1-1/2"	130	124	420
1"X2(2-1/2)"	134	125	440
1-1/2"X2-1/2"(3")	150	140	560
2"X3"	155	150	590
3"X4"	185	170	740
4"X6"	225	200	890
6"X8"	256	240	1080
6"X10"	282	269	1130
8"X10"	310	280	1280

Unit: mm



PILOT-OPERATED SAFETY RELIEF VALVE

- Cast Steel Safety Valve, Angle Pattern
- Self-actuated Auxiliary Pressure Relief Valve Controlled
- Available In Both Pop and Modulating Action Designs
- Spring Loaded, Auxiliary balancing piston
- Designed to ISO 4126, API Rp520

Face to Face	API 526
End Flange	ASME B16.5a
Class	ASME CL150~1500

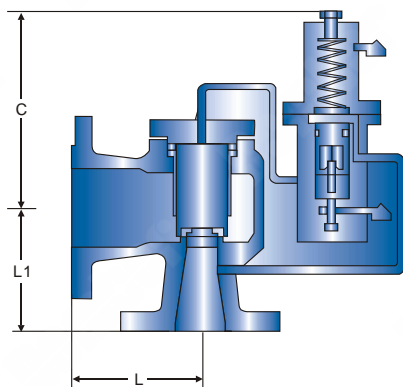

DB-A46

CLASS 150-1500 DIMENSION

SIZE(in.)	1x2	1x2	1x2	1x2	1x2	1x2	1-1/2x2	1-1/2x2	1-1/2x2	1-1/2x2	1-1/2x2
ORIFICE	D.E.F	D.E.F	D.E.F	D.E.F	D.E.F	D.E.F	D.E.F	D.E.F	D.E.F	D.E.F	D.E.F
INLET CLASS	150	300	600	900	1500	2500	150	300	600	900	1500
OUTLET CLASS	150	150	150	300	300	300	150	150	150	300	300
L	115	115	115	121	121	121	121	121	121	140	140
L1	105	105	105	125	125	125	124	124	124	149	149
C	406	406	406	508	508	508	432	432	432	533	533
SIZE(in.)	2x3	2x3	2x3	2x3	2x3	2x3	3x4	3x4	3x4	3x4	3x4
ORIFICE	G.H.J	G.H.J	G.H.J	G.H.J	G.H.J	G.H.J	J,K,L	J,K,L	J,K,L	J,K,L	J,K,L
INLET CLASS	150	300	600	900	1500	2500	150	300	600	900	1500
OUTLET CLASS	150	150	150	300	300	300	150	150	150	300	300
L	124	124	124	171	171	171	162	162	162	181	181
L1	130	130	130	167	167	178	156	156	162	190	190
C	457	457	457	559	559	584	483	483	483	610	610

Unit: mm

SIZE(in.)	1-1/2x2	1-1/2x3	1-1/2x3	1-1/2x3	1-1/2x3	1-1/2x3	1-1/2x3	6x8	6x8	6x8
ORIFICE	D.E.F	G.H	G.H	G.H	G.H	G.H	G.H	Q.R	Q.R	Q.R
INLET CLASS	2500	150	300	600	900	1500	2500	150	300	600
OUTLET CLASS	300	130	130	130	162	162	162	150	150	150
L	140	124	124	124	171	171	171	241	241	241
L1	149	130	130	130	162	162	162	240	240	240
C	533	457	457	457	559	559	559	635	635	635
SIZE(in.)	3x4	4x6	4x6	4x6	4x6	4x6	4x6	8x10	8x10	8x10
ORIFICE	J,K,L	L.M.N.P	L.M.N.P	L.M.N.P	L.M.N.P	L.M.N.P	L.M.N.P	T	T	T
INLET CLASS	150	300	600	900	1500	1500	150	300	600	
OUTLET CLASS	150	150	150	300	300	600	150	150	150	
L	229	229	229	229	233	233	264	279	279	279
L1	181	181	181	181	249	249	249	276	276	297
C	559	559	559	559	711	711	711	711	711	737

Unit: mm

SPECIAL SAFETY VALVE SERIES FOR OIL REFINING

- Special Safety Relief Valve, Angle Pattern
- Cast steel bonnet and cap, corrosion resistant trim
- Designed to ISO 4126, API Rp520

Face to Face	API 526
End Flange	ASME B16.5a
Class	ASME CL150

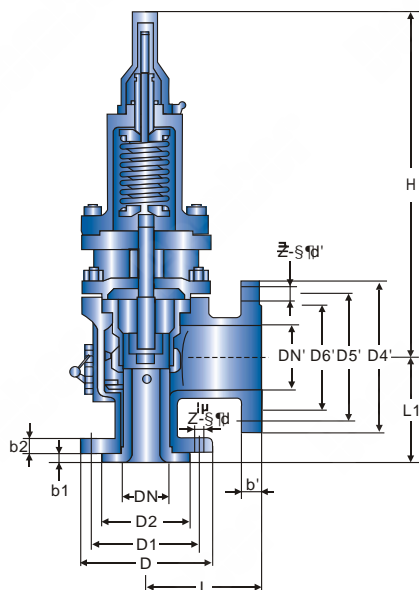

DB-TA

TECHNICAL PARAMETER ● TYPE-A

TYPE	INLET FLANGE			CODE	NOZZLE		OPERATING TEMP
	DN(mm)	PN(Mpa)	CP(Mpa)		THROAT DIA(mm)	THROAT AREA(mm ²)	
A1D40	25	4.0	0.03-4.2	D	10	0.78	-25~300
A15F40	40	4.0	0.03-4.2	F	16	2.0	-25~300
A2J16	50	1.6	0.03-<1.6	J	34	9.1	-25~300
A2H40	50	4.0	1.6-4.2	H	26	5.3	-25~300
A3L16	80	1.6	0.03-<1.6	L	50	19.6	-25~300
A3K40	80	4.0	1.6-4.2	K	40	12.6	-25~300
A4P16	100	1.6	0.03-<1.6	P	72	40.7	-25~300
A4N40	100	4.0	1.6-4.2	N	60	28.3	-25~300
A6R5.5	150	1.6	0.03-<0.55	R	115	104	-25~300
A6Q16	150	1.6	0.55-1.1	Q	95	71	-25~300

TECHNICAL PARAMETER ● TYPE-TA

TYPE	INLET FLANGE			CODE	NOZZLE		OPERATING TEMP
	DN(mm)	PN(Mpa)	CP(Mpa)		THROAT DIA(mm)	THROAT AREA(mm ²)	
TA1D40	25	4.0	0.03-4.2	D	10	0.78	>300~500
TA1.5F40	40	4.0	0.03-4.2	F	16	2.0	>300~500
TA2J16	50	1.6	0.03-<1.6	J	34	9.1	>300~500
TA2H40	50	4.0	1.6-4.2	H	26	5.3	>300~500
TA3L16	80	1.6	0.03-<1.6	L	50	19.6	>300~500
TA3K40	80	4.0	1.6-4.2	K	40	12.6	>300~500
TA4P16	100	1.6	0.03-<1.6	P	72	40.7	>300~500
TA4N40	100	4.0	1.6-4.2	N	60	28.3	>300~500
TA6R5.5	150	1.6	0.03-<0.55	R	115	104	>300~500
TA6Q16	150	1.6	0.55-1.1	Q	95	71	>300~500

SPECIAL SAFETY VALVE SERIES FOR OIL REFINING

- Special Safety Relief Valve, Angle Pattern
- Cast steel bonnet and cap, corrosion resistant trim
- Designed to ISO 4126, API Rp520

Face to Face	API 526
End Flange	ASME B16.5a
Class	ASME CL150

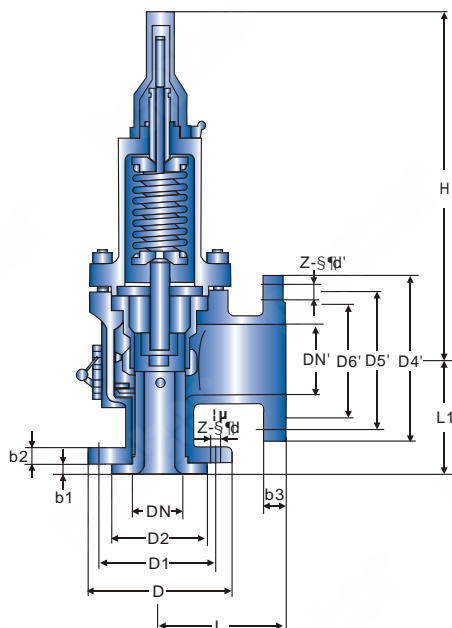

DB-A

TYPE DB-ADIMENSION

TYPE	L	L1	D1	D2	D3	D4'	D5'	b1	b2	b3	z-S'φd	z'-S'φd"	H
													Unit: mm
A1D40	99	100	115	85	57	160	125	9	19	16	4-S'φ14	4-S'φ18	327
A1.5F40	107	120	145	110	75	160	125	13	20	16	4-S'φ18	4-S'φ18	336
A2J16	139	150	160	125	92	195	160	14	22	20	4-S'φ18	8-S'φ18	409
A2H40	139	150	160	125	87	195	160	14	22	20	4-S'φ18	8-S'φ18	487
A3L16	147	160	195	160	133	215	180	12	22	20	8-S'φ18	8-S'φ18	489
A3K40	149	160	195	160	120	215	180	16	24	20	8-S'φ18	8-S'φ18	596
A4P16	176	200	215	180	153	280	240	13	22	24	8-S'φ23	8-S'φ23	639.5
A4N40	182.5	200	230	190	149	280	240	17.5	26	24	8-S'φ23	12-S'φ23	757
A6R5.5	228	230	280	240	195	335	295	18	24	26	8-S'φ23	12-S'φ23	775
A6Q16	228	230	280	240	189	335	295	18	24	26	8-S'φ23	12-S'φ23	775

TYPE DB-TA DIMENSION

TYPE	L	L1	D1	D2	D3	D4'	D5'	b1	b2	b3	z-S'φd	z'-S'φd"	H
													Unit: mm
TA1D40	99	100	115	85	57	160	125	9	19	16	4-S'φ14	4-S'φ18	424.5
TA1.5F40	107	120	145	110	75	160	125	13	20	16	4-S'φ18	4-S'φ18	443.5
TA2J16	139	150	160	125	92	195	160	14	22	20	4-S'φ18	8-S'φ18	539.5
TA2H40	139	150	160	125	87	195	160	14	22	20	4-S'φ18	8-S'φ18	652
TA3L16	147	160	195	160	133	215	180	12	22	20	8-S'φ18	8-S'φ18	654
TA3K40	149	160	195	160	120	215	180	16	24	20	8-S'φ18	8-S'φ18	789
TA4P16	176	200	215	180	153	280	240	13	22	24	8-S'φ23	8-S'φ23	832.5
TA4N40	182.5	200	230	190	149	280	240	17.5	26	24	8-S'φ23	12-S'φ23	976
TA6R5.5	228	230	280	240	195	335	295	18	24	26	8-S'φ23	12-S'φ23	986
TA6Q16	228	230	280	240	189	335	295	18	24	26	8-S'φ23	12-S'φ23	986

THREADED SAFETY RELIEF VALVE

- Conventional Safety Relief Valve, Angle Pattern
- Cast Steel Bonnet and Cap, Corrosion Resistant Trim
- Spring Loaded, Male, Female Threaded or Flanged Ends
- Designed to ISO 4126, API RP520

Face to Face	API 526
End Flange	ASME B16.5a
Class	ASME CL150-CL1500

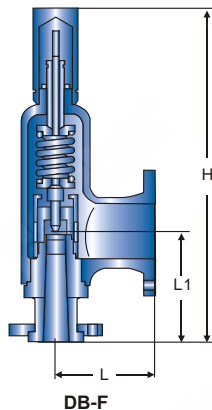
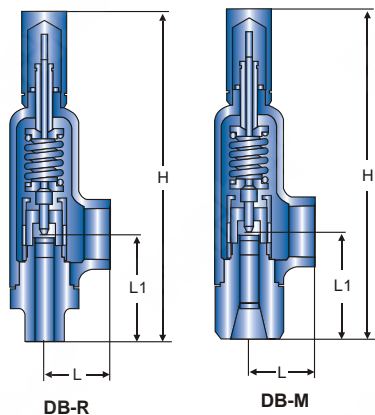

CLASS 150-1500 DIMENSION

INLET* ORIFICE* OUTLET	END (NPT)		MAX. SET PRESSURE (BAR)	DB-R, DB-M			DB-F			
	Inlet	Outlet		L	L1	H	L	L1	H	
1/4"B1/4"	Female Male	Female	-29~ 232°C	232~ 427°C	L	L1	H	L	L1	H
1/2"B1/2"	Female Male	Female	85.1	56.8	50 50	77 54	240 220	108 108	118 118	280 280
1/2"C1/2"	Female Male	Female	85.1	56.8	50 50	77 54	240 220	108 108	118 118	280 280
3/4"C3/4"	Female Male	Female	85.1	56.8	50 50	77 54	240 220	108 108	118 118	280 280
3/4"C 1"	Female Male	Female	85.1	56.8	50 50	77 54	240 220	108 108	118 118	280 280
1" C 1"	Female Male	Female	85.1	56.8	50 50	77 54	240 220	108 108	118 118	280 280
3/4"D3/4"	Female Male	Female	85.1	56.8	50 50	77 54	240 220	108 108	118 118	280 280
3/4"D 1"	Female Male	Female	85.1	56.8	50 50	77 54	240 220	108 108	118 118	280 280
1" D 1"	Female Male	Female	85.1	56.8	50 50	77 54	240 220	108 108	118 118	280 280

Unit: mm

PRESSURE RELIEF VALVE

- Pressure relief valve, low pressure and vacuum
- Cast steel bonnet and cap, corrosion resistant trim
- Angle pattern, equipped with pilot device
- Designed to ISO 4126, API RP520

Face to Face	API 526
End Flange	ASME B16.5a
Class	ASME CL150

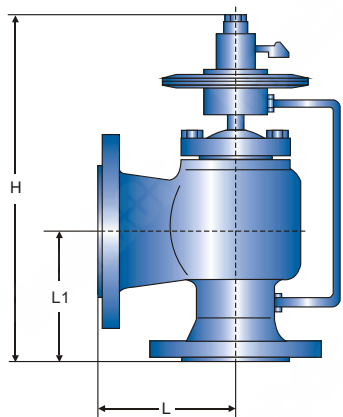

DB-JY

CLASS 150 DIMENSION

SIZE (in.)	L	L1	H
2"X3"	127	95	425
3"X4"	146	114	460
4"X6"	178	140	515
6"X8"	236	171	585
8"X10"	279	203	635
10"X12"	318	241	675
12"X16"	362	298	815

Unit: mm

FEATURES

DBV needle valves are for use in general purpose applications to isolate or vent system media. The hardened stainless steel, non-rotating needle promotes leak-tight shutoff and long service life. The valve stem threads are isolated from the media. Compact design
 Stainless steel stoppin
 Antitamper and lockable handle features available
 Suitable for sour gas service; materials for wetted components selected in accordance with NACE standard MR0175/ISO 15156.



DESIGN FEATURES

Stainless steel handle with square drive stem and lock nut to ensure positive actuation

Stem threads are cold rolled for high strength and smooth operation

Two-piece knuckle joint provides nonrotating needle feature. Joint is located above the packing, protected from system media

Nonrotating, hardened needle for positive shutoff

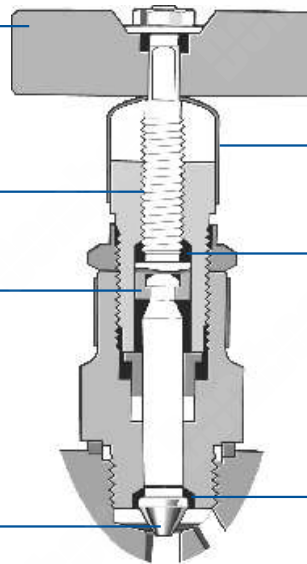

Shroud protects stem threads against ingress of dirt and dust

Stem threads above packing, protected from system media

Safety back-seating needle seals in fully open position

MATERIALS OF CONSTRUCTION

COMPONENT	MATERIAL GRADE/ASTM SPECIFICATION	
	STAINLESS STEEL	CARBON STEEL
Body	316/316L SS/A479	Zinc plated carbon steel/AISI 1018
Bonnet	316/316L SS/A479	316/316L SS/A479
Needle	S17400 SS/A564 Condition H1150D	
Packing Bonnet seals	PTFE	
Lubricant	Fluorinated base with PTFE and tungsten disulfide	
Bonnet seal ring	316 SS	

PRESSURE-TEMPERATURE RATINGS RATINGS ARE BASED ON PTFE PACKING.

TEMPERATURE ° F (° C)	WORKING PRESSURE PSIG (BAR)	
	316/316L SS	CARBON STEEL
0 to 200 (- 28 to 93)	6000 (413)	6000 (413)
450 (232)	4000 (275)	4000 (275)

FLOW COEFFICIENT (CV) VS TURNS OPEN

ANGLE PATTERN

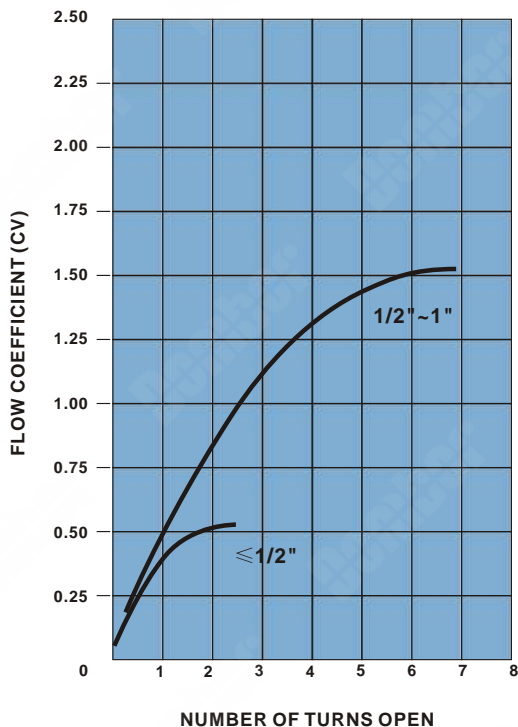

STRAIGHT PATTERN

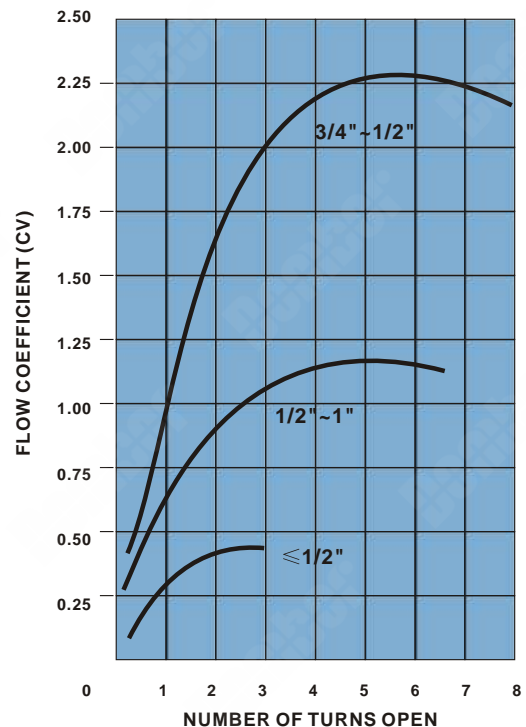

NEEDLE VALVE

- Steel Needle Valve, Straight Through
- Threaded Ends, Plug Type
- Designed to ASME B16.34

Face to Face	ASME/ANSI B16.10
End Flange	ASME/ANSI B16.5
Butt Weld	ASME/ANSI B16.25
Class	1000PSI-6000PSI

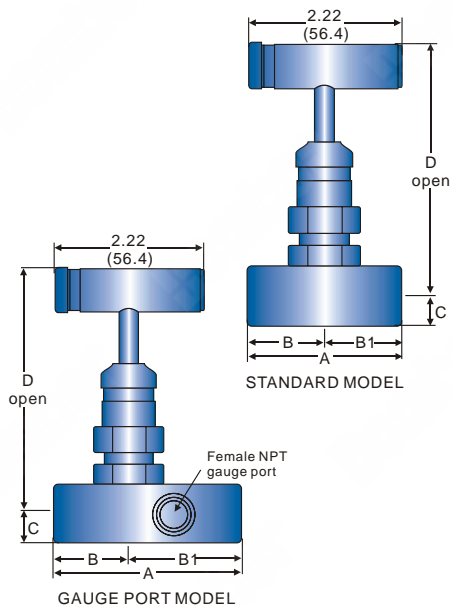

DIMENSION

END	SIZE (in.)	CV	ORIFICE	MODEL	A	B	B1	C	D
Unit: inch									
Female NPT	1/4	0.63	0.187	Standard	2.24	1.12	1.12	0.44	3.77
				Gauge Port	2.87	1.12	1.75	0.50	3.77
Male/ female NPT	1/2	1.80	0.250	Standard	2.66	1.33	1.33	0.56	3.83
				Gauge Port	3.58	1.33	2.25	0.56	3.83
	1/4	0.63	0.187	Standard	2.90	1.78	1.12	0.44	3.77
	1/2 to 1/4	0.63	0.187	Standard	3.01	1.89	1.12	0.44	3.77
	1/4			Gauge Port	4.87	3.12	1.75	0.50	3.77
	1/2	1.80	0.250	Standard	3.49	2.16	1.33	0.56	3.83
			Gauge Port	5.58	3.33	2.25	0.56	3.83	
	3/4 to 1/2	1.80	0.250	Standard	3.49	2.16	1.33	0.56	3.83
	1/2			Gauge Port	5.58	3.33	2.25	0.56	3.83



NEEDLE VALVE

- Steel Needle Valve, Threaded Ends
- Straight Through or Angle Pattern
- Designed to ASME B16.34

Face to Face	DBV Standard
End Flange	ASME/ANSI B16.5
Socket Weld	ASME/ANSI B16.11
Class	1000PSI-3000PSI

FLOW DATA AT 100° F (37° C) FLOW COEFFICIENT AT TURNS OPEN

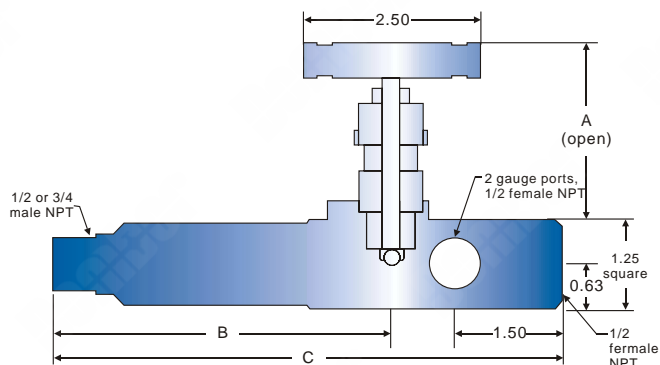
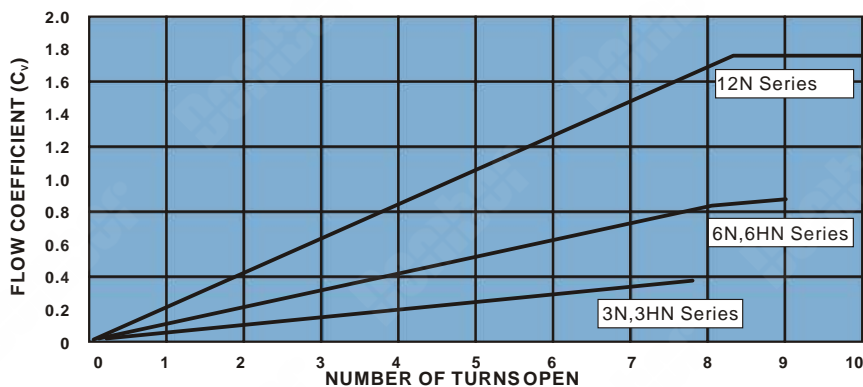

Ball-Tip Design Valve with Lagging Extension Body

DIMENSION

STEM DESIGN	END	SEAT	ORIFICE	A	B	C
Unit: inch						
Ball tip	1/2	316 SS	0.156	3.88	2.97	5.38
	Lagging 1/2 to 1/2	316 SS	0.156	3.88	4.84	7.25
	3/4 to 1/2	316 SS	0.156	3.88	2.97	5.38
Plug	Lagging 3/4 to 1/2	316 SS	0.156	3.88	4.84	7.25
	1/2 to 1/2	Acetal	0.250	3.54	2.97	5.38
	3/4 to 1/2	PFA	0.250	3.54	2.97	5.38
	1/2 to 1/2	PEEK	0.250	3.54	2.97	5.38
	3/4 to 1/2					

NEEDLE VALVE

- Steel Needle Valve, Threaded Ends
- Straight Through or Angle Pattern
- Designed to ASME B16.34

Face to Face	DBV Standard
End Flange	ASME/ANSI B16.5
Socket Weld	ASME/ANSI B16.11
Class	1000PSI~6000PSI

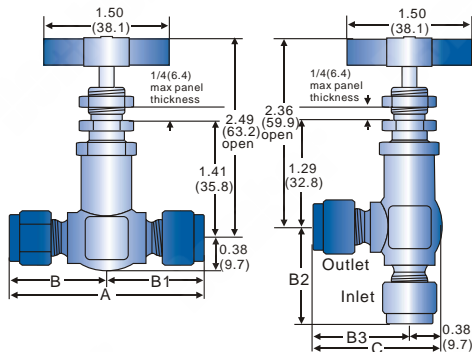

DIMENSION

END	SIZE	ORIFICE	A	B	B1	B2	B3	C	Unit: inch
Male NPT	1/8	0.156	1.75	0.88	0.88	-	-	-	-
	1/4	0.166	2.00	1.00	1.00	1.00	1.00	1.37	-
Male NPT to male ISO	1/4	0.166	2.00	1.00	1.00	1.00	1.00	1.37	-
Female NPT	1/8	0.166	2.00	1.00	1.00	0.88	0.88	1.25	-

Note: Cv Value for Straight Pattern=0.39
Cv Value for Angle Pattern= 0.58

NEEDLE VALVE

- Steel Needle Valve, Threaded Ends
- Straight Through, Non-rotating Stem
- Designed to ASME B16.34

Face to Face	DBV Standard
End Flange	ASME/ANSI B16.5
Socket Weld	ASME/ANSI B16.11
Class	1000PSI~10000PSI

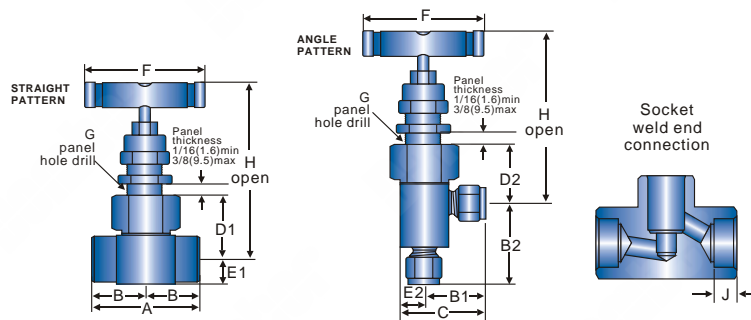

DIMENSION

END	SIZE	CV	A	B	B1	B2	C	D1	D2	E1	E2	F	G	H	H	J	Unit: inch
																STRAIGHT ANGLE	
																0.156 inch Orifice	
Female NPT	1/8	0.35	2.00	1.00	0.89	1.00	1.27	1.09	1.28	0.38	0.38	1.75	19/32	3.04	3.23	-	-
Male NPT	1/4	0.35	2.06	1.03	0.89	1.00	1.27	1.09	1.28	0.39	0.38	1.75	19/32	3.04	3.23	-	-
Male NPT	1/4	0.35	2.00	1.00	1.00	1.00	1.38	1.09	1.09	0.38	0.38	1.75	19/32	3.04	3.04	-	-
Male/female NPT	1/4	0.35	2.03	1.03	0.89	1.00	1.27	1.09	1.28	0.39	0.38	1.75	19/32	3.04	3.23	-	-
Tube socket welds	1/4	0.35	1.82	0.91	0.88	1.19	1.25	1.09	1.09	0.38	0.38	1.75	19/32	3.04	3.23	0.28	-
Male VCO fittings	1/4	0.35	2.06	1.03	0.88	1.19	1.25	1.09	1.09	0.38	0.38	1.75	19/32	3.04	3.23	-	-
Male VCR fittings	1/4	0.35	2.06	1.03	-	-	-	1.09	-	0.38	-	1.75	19/32	3.04	3.23	-	-
																0.250 inch Orifice	
Female NPT	1/4	0.86	2.25	1.12	1.00	1.12	1.50	1.34	1.47	0.50	0.50	2.50	25/32	3.70	3.82	-	-
	3/8	0.86	2.25	1.12	1.00	1.12	1.50	1.34	1.47	0.50	0.50	2.50	25/32	3.70	3.82	-	-
Tube socket welds	3/8	0.86	2.25	1.12	1.00	1.25	1.50	1.34	1.34	0.50	0.50	2.50	25/32	3.70	3.70	0.31	-
Pipe socket welds	1/2	0.86	2.25	1.12	1.00	1.00	1.50	1.34	1.40	0.50	0.50	2.50	25/32	3.70	3.76	0.38	-
Male VCO fittings	1/4	0.86	2.25	1.12	1.00	1.12	1.50	1.34	1.47	0.50	0.50	2.50	25/32	3.70	3.82	0.38	-
Male VCO fittings	1/2in.	0.86	2.25	1.12	-	-	-	-	-	-	-	-	-	-	-	-	-
Male VCR fittings	1/2in.	0.86	3.12	1.56	-	-	-	-	1.53	-	0.62	-	2.50	25/32	3.88	-	-

NEEDLE VALVE

- Steel Needle Valve, Threaded Ends
- Angle Pattern, Non-rotating
- Hardened Needle
- Designed to ASME B16.34

Face to Face	DBV Standard
End Flange	ASME/ANSI B16.5
Socket Weld	ASME/ANSI B16.11
Class	1000PSI~4000PSI

ANGLE PATTERN

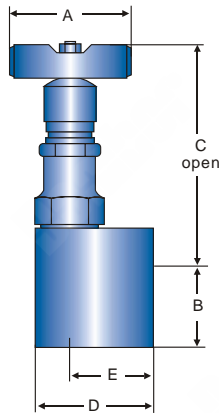

STRAIGHT PATTERN

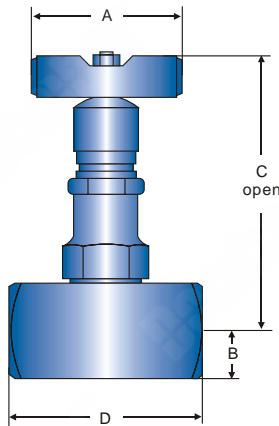

ANGLE PATTERN

END	SIZE	CV	ORIFICE	A	B	C	D	E
Unit: inch								
Female NPT	1/4	0.55	0.20	1.75	0.85	3.20	1.50	1.00
	3/8	0.55	0.20	1.75	1.10	3.20	1.75	1.25
	1/2	0.55	0.20	1.75	1.23	3.33	2.00	1.31
Female NPT	1/2	1.60	0.31	2.00	1.23	3.87	2.00	1.38
	3/4	1.60	0.31	2.00	1.60	3.98	2.50	1.50
	1	1.60	0.31	2.00	1.60	4.25	2.75	1.75

STRAIGHT PATTERN

END	SIZE	CV	ORIFICE	A	B	C	D
Unit: inch							
Female NPT	1/4 in.	0.45	0.20	1.75	0.50	3.20	2.13
	3/8 in.	0.45	0.20	1.75	0.50	3.20	2.25
	1/2 in.	0.45	0.20	1.75	0.63	3.33	2.63
	3/4 in.	1.20	0.31	2.00	0.75	3.98	3.00
	1 in.	1.20	0.31	2.00	1.00	4.25	3.50
Male NPT/ female NPT	1/4 in.	0.45	0.20	1.75	0.50	3.20	2.38
	3/8 in.	0.45	0.20	1.75	0.50	3.20	2.38
	1/2 in.	0.45	0.20	1.75	0.63	3.33	2.75
	3/4 in.	1.20	0.31	2.00	0.75	3.98	3.13
	1 in.	1.20	0.31	2.00	1.00	4.25	3.50
Fractional tube socket weld	1/4 in.	0.45	0.20	1.75	0.50	3.20	2.00
	3/8 in.	0.45	0.20	1.75	0.50	3.20	2.00
	1/2 in.	0.45	0.20	1.75	0.50	3.20	2.25
	3/4 in.	1.20	0.31	2.00	0.63	3.87	2.63
	1 in.	1.20	0.31	2.00	0.75	3.98	2.63
Fractional pipe socket weld	1/4 in.	0.45	0.20	1.75	0.50	3.20	2.25
	3/8 in.	0.45	0.20	1.75	0.63	3.33	2.25
	1/2 in.	0.45	0.20	1.75	0.75	3.45	2.50
	3/4 in.	1.20	0.31	2.00	0.88	4.13	3.25
	1 in.	1.20	0.31	2.00	1.00	4.25	3.25
Metric tube socket weld	6mm	0.45	0.20	1.75	0.50	3.20	2.38
	8mm	0.45	0.20	1.75	0.50	3.20	2.00
	10mm	0.45	0.20	1.75	0.50	3.20	2.00
	12mm	0.45	0.20	1.75	0.50	3.20	2.25
	14mm	1.20	0.31	2.00	0.63	3.87	2.63
	16mm	1.20	0.31	2.00	0.63	3.87	2.63
	18mm	2.25	0.43	3.00	0.88	5.24	3.25
25mm	2.25	0.43	3.00	0.88	5.24	3.25	

NEEDLE VALVE

- Steel Needle Valve, Threaded Ends
- Straight Through, Non-rotating Stem
- Designed to ASME B16.34

Face to Face	DBV Standard
End Flange	ASME/ANSI B16.5
Socket Weld	ASME/ANSI B16.11
Class	1000PSI~10000PSI

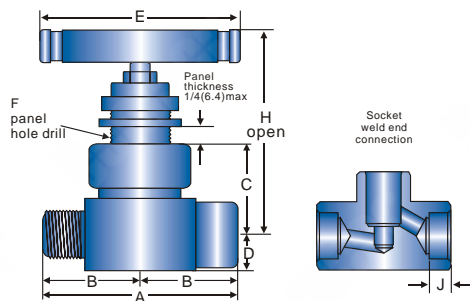

DIMENSION

END	SIZE	A	B	C	D	E	F	H	J
Unit: inch									
0.156 inch Orifice									
Female NPT	1/8 in.	2.25	1.13	1.38	0.50	2.50	0.81	3.31	-
	1/4 in.	2.25	1.13	1.38	0.50	2.50	0.81	3.31	-
Male NPT	1/4 in.	2.25	1.13	1.38	0.50	2.50	0.81	3.31	-
Male/ femaleNPT	1/4 in.	2.25	1.13	1.38	0.50	2.50	0.81	3.31	-
Tube socket welds	1/4 in.	2.25	1.13	1.38	0.50	2.50	0.81	3.31	0.28
0.250 inch Orifice									
Female NPT	1/4	3.13	1.56	1.81	0.63	3.50	1.06	4.13	-
	1/2	3.25	1.63	1.94	0.78	3.50	1.06	4.25	-
Male NPT	1/2	3.13	1.56	1.81	0.63	3.50	1.06	4.13	-
Male/ femaleNPT	1/2	3.25	1.63	1.94	0.78	3.50	1.06	4.25	-

NEEDLE VALVE BLOW DOWN

- Steel Needle Valve, Threaded Ends
- Straight Through or Angle Pattern
- Non-rotating, Hardened Needle
- Designed to ASME B16.34

Face to Face	DBV Standard
End Flange	ASME/ANSI B16.5
Socket Weld	ASME/ANSI B16.11
Class	1000PSI-6000PSI

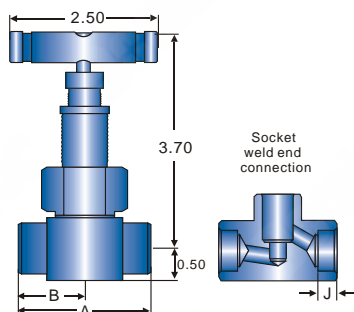

PRESSURE-TEMPERATURE RATINGS

ASME Class	2500
Material Group	Working Pressure psig (bar)
Material	316 SS
Temperature	2.2

-65 (-53) to 100 (37)	6000 (413)
200 (93)	5160 (355)
250 (121)	4910 (338)
300 (148)	4660 (321)
350 (176)	4470 (307)
400 (204)	4280 (294)
450 (232)	4130 (284)
500 (260)	3980 (274)
600 (315)	3760 (259)
650 (343)	3700 (254)
700 (371)	3600 (248)
750 (398)	3520 (242)
800 (426)	3460 (238)
850 (454)	3380 (232)
900 (482)	3280 (225)
950 (510)	3220 (221)
1000 (537)	3030 (208)
1050 (565)	3000 (206)
1100 (593)	2685 (184)
1150 (621)	2285 (157)
1200 (648)	1715 (118)

DIMENSION

END	SIZE	A	B	J	Unit: inch
Female NPT	1/4	2.25	1.12	-	
	3/8	2.25	1.12	-	
Tube socket weld	3/8	2.25	1.12	0.31	
	1/2	2.25	1.12	0.31	
Pipe socket weld	1/4	2.25	1.12	0.38	

NEEDLE VALVE BLOW DOWN

- Steel Needle Valve, Threaded Ends
- Straight Through or Angle Pattern
- Non-rotating, Hardened Needle
- Designed to ASME B16.34

Face to Face	DBV Standard
End Flange	ASME/ANSI B16.5
Socket Weld	ASME/ANSI B16.11
Class	1000PSI-3000PSI

OPERATING TORQUE

Torque required for shutoff at maximum pressure rating is 50 in. lb (5.7 N.m). Overtightening of valve will result in reduced seat life.

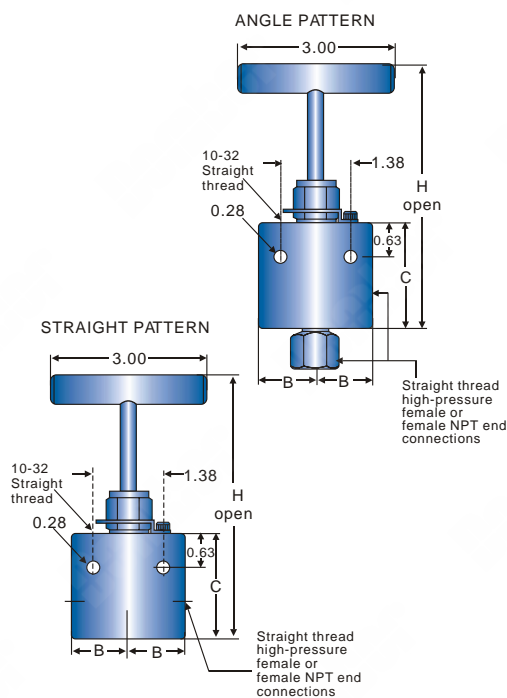
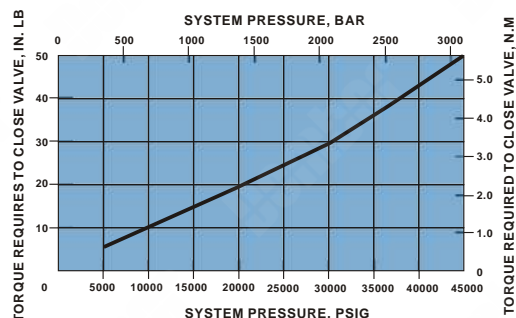

SIZE (in.)	PORT THREAD SIZE	CV	ORIFICE	B	C	H	Unit: inch
STRAIGHT PATTERN							
1/4	1/4 in. Female NPT	0.12	0.093	1.07	2.02	4.91	
1/4	9-16/18	0.12	0.093	1.07	2.02	4.91	
3/8	3/4-16	0.14	0.093	1.39	2.27	5.16	
9/16	1-1/8-12	0.14	0.093	1.39	2.58	5.47	
ANGLE PATTERN							
1/4	1/4 in. Female NPT	0.15	0.093	1.39	2.27	5.47	
1/4	9-16/18	0.15	0.093	1.39	2.02	4.91	
3/8	3/4-16	0.19	0.093	1.39	2.27	5.16	
9/16	1-1/8-12	0.19	0.093	1.39	2.58	5.47	

Dombor

Innovation. Ingenuity. Infinity.

Inquiries

+86-0577-67387722
dombor@dombor.com

Head Office

No.96 Fanhua East Road,Oubei Wenzhou,Zhejiang China

